



COPY RIGHT

2017 IJIEMR. Personal use of this material is permitted. Permission from IJIEMR must be obtained for all other uses, in any current or future media, including reprinting/republishing this material for advertising or promotional purposes, creating new collective works, for resale or redistribution to servers or lists, or reuse of any copyrighted component of this work in other works. No Reprint should be done to this paper, all copy right is authenticated to Paper Authors

IJIEMR Transactions, online available on 17th October 2017. Link :

<http://www.ijiemr.org/downloads.php?vol=Volume-6&issue=ISSUE-11>

Title: A Grid-Connected Dual Voltage Source Inverter With Power Quality Improvement Features By Using Fuzzy Logic Controller.

Volume 06, Issue 11, Page No: 33 – 42.

Paper Authors

* **BANOTH VIJAYA, BADHAVATH PRASAD.**

* Ellenki College of Engineering and Technology.



USE THIS BARCODE TO ACCESS YOUR ONLINE PAPER

To Secure Your Paper As Per **UGC Guidelines** We Are Providing A Electronic Bar Code

A GRID-CONNECTED DUAL VOLTAGE SOURCE INVERTER WITH POWER QUALITY IMPROVEMENT FEATURES BY USING FUZZY LOGIC CONTROLLER

*BANOTH VIJAYA, **BADHAVATH PRASAD

*Ellenki College of Engineering and Technology, Patalguda Village, Patancheru Mandal, Medhak District.

**Ellenki College of Engineering and Technology, Patalguda Village, Patancheru Mandal, Medhak District.

Badhavath.prasad5@gmail.com

Bvijaya203@gmail.com

ABSTRACT: The main aim of project is to improve the power quality by using fuzzy based grid connected dual voltage source inverter. The proposed scheme is comprised of two inverters, which enables the micro grid to exchange power generated by the distributed energy resources (DERs) and also to compensate the local unbalanced and nonlinear load. The control algorithms are developed based on instantaneous symmetrical component theory (ISCT) to operate DVSI in grid sharing and grid injecting modes. The proposed scheme has increased reliability, lower bandwidth requirement of the main inverter, lower cost due to reduction in filter size, and better utilization of micro grid power while using reduced dc-link voltage rating for the main inverter. These features make the DVSI scheme a promising option for micro grid supplying sensitive loads. the proposed topology validated through simulation results.

Keywords: Power Quality, Distributed Energy Source, Fuzzy Controller, Grid Connected Inverter, Instantaneous Symmetrical Component Theory (ISCT).

I. INTRODUCTION

The proliferation of power electronics devices and electrical loads with unbalanced nonlinear currents has degraded the power quality in the power distribution network. Moreover, if there is a considerable amount of feeder impedance in the distribution systems, the propagation of these harmonic currents distorts the voltage at the point of common coupling (PCC). At the same instant, industry automation has reached to a very high level of sophistication, where plants like automobile manufacturing units, chemical factories, and semiconductor industries require clean power. For these applications, it is essential to compensate nonlinear and unbalanced load currents. Load compensation and power injection using grid interactive inverters in micro grid have been presented in

the literature. A single inverter system with power quality enhancement is discussed in. The main focus of this work is to realize dual functionalities in an inverter that would provide the active power injection from a solar PV system and also works as an active power filter, compensating unbalances and the reactive power required by other loads connected to the system. In , a voltage regulation and power flow control scheme for a wind energy system (WES) is proposed. A distribution static compensator (DSTATCOM) is utilized for voltage regulation and also for active power injection. The control scheme maintains the power balance at the grid terminal during the wind variations using sliding mode control. A multifunctional power electronic converter for the DG power system is described in. This scheme has the capability to

inject power generated by WES and also to perform as a harmonic compensator. Most of the reported literature in this area discuss the topologies and control algorithms to provide load compensation capability in the same inverter in addition to their active power injection. When a grid-connected inverter is used for active power injection as well as for load compensation, the inverter capacity that can be utilized for achieving the second objective is decided by the available instantaneous micro grid real power. Considering the case of a grid-connected PV inverter, the available capacity of the inverter to supply the reactive power becomes less during the maximum solar insolation periods. At the same instant, the reactive power to regulate the PCC voltage is very much needed during this period. It indicates that providing multi functionalities in a single inverter degrades either the real power injection or the load compensation capabilities. This paper demonstrates a dual voltage source inverter (DVSI) scheme, in which the power generated by the micro grid is injected as real power by the main voltage source inverter (MVSI) and the reactive, harmonic, and unbalanced load compensation is performed by auxiliary voltage source inverter (AVSI). This has an advantage that the rated capacity of MVSI can always be used to inject real power to the grid, if sufficient renewable power is available at the dc link. In the DVSI scheme, as total load power is supplied by two inverters, power losses across the semiconductor switches of each inverter are reduced. This increases its reliability as compared to a single inverter with multifunctional capabilities. Also, smaller size modular inverters can operate at high switching frequencies with a reduced size of interfacing

inductor, the filter cost gets reduced. Moreover, as the main inverter is supplying real power, the inverter has to track the fundamental positive sequence of current. This reduces the bandwidth requirement of the main inverter. The inverters in the proposed scheme use two separate dc links. Since the auxiliary inverter is supplying zero sequence of load current, a three-phase three-leg inverter topology with a single dc storage capacitor can be used for the main inverter. This in turn reduces the dc-link voltage requirement of the main inverter. Thus, the use of two separate inverters in the proposed DVSI scheme provides increased reliability, better utilization of micro grid power, reduced dc grid voltage rating, less bandwidth requirement of the main inverter, and reduced filter size. Control algorithms are developed by instantaneous symmetrical component theory (ISCT) to operate DVSI in grid-connected mode, while considering non stiff grid voltage.

II. FUZZY LOGIC CONTROLLER

Fuzzy logic is an innovative technology that enhances conventional system design with engineering expertise. Using fuzzy logic, we can circumvent the need for rigorous mathematical modeling. A human operator is far more successful in controlling a process than a controller designed by modern analytical technique. So it is worth simulating the control strategy based upon intuition and experience and can be considered as heuristic decision or rule of thumb decision. In academic and technological arena, Fuzzy is a technical term that deals with ambiguity or vagueness based on human intuitions. Professor Lotfi A Zadeh introduced the concept of fuzzy sets, according to him. Fuzzy logic is a mathematical imprecise description. During the past several years, FLC has emerged as one of the most active area of

research for the application of fuzzy set theory. A fuzzy set is a generalization of the concept of an ordinary set in which the membership function (MF) values can be only one of the two values, 0 and 1. A fuzzy set can be defined as below. Fuzzy set A in a universe of discourse U is characterized by a MF $\mu_A: U \rightarrow [0, 1]$ and associates with each element x of U a number $\mu_A(x)$ in the interval [0, 1] representing the degree of membership of x in A.

A. Fuzzy Controller Model

Fuzzy modeling is the method of describing the characteristics of a system using fuzzy inference rules. The method has a distinguishing feature in that it can express linguistically complex non-linear system.

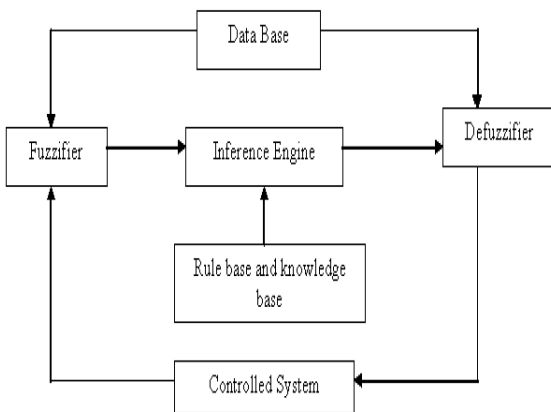

Fig.1. Structure of Fuzzy Logic Controller

It is however, very hard to identify the rules and tune the membership functions of the reasoning. Fuzzy Controllers are normally built with fuzzy rules. These fuzzy rules are obtained either from domain experts or by observing the people who are currently doing the control. The membership functions for the fuzzy sets will be derive from the information available from the domain experts and/or observed control actions. The building of such rules and membership functions require tuning. That is, performance of the controller must be measured and the

membership functions and rules adjusted based upon the performance. This process will be time

consuming. The basic configuration of Fuzzy logic control based as shown in Fig. 4.1 consists of four main parts i.e. (i) Fuzzification, (ii) knowledge base, (iii) Inference Engine and (iv) Defuzzification.

1. Fuzzification

Fuzzification maps from the crisp input space to fuzzy sets in certain, input universe of discourse. So for a specific input value x, it is mapped to the degree of membership $\mu_A(x)$. The fuzzification involves the following functions. Measures the value of input variables.
 □ Performs a scale mapping that transfers the range of values of input variables into corresponding universe of discourse.

□ Performs the function of fuzzification that converts input data into suitable linguistic variables, which may be viewed as labels of fuzzy sets.

The input variables to fuzzifier are the crisp controlled variables. Selection of the control variables relies on the nature of the system and its desired output. It is more common in the literature to use the output error and the derivative of output. Each of the fuzzy logic control (FLC) input and output signal is interpreted into a number of linguistic variables. The number of linguistic variables specifies the quality of control which can be achieved using the fuzzy controller. As the number of linguistic variables increases, the computational time and required memory increases. Therefore a compromise between the quality of control and computational time is needed to choose the number is seven. Each linguistic variables NB, NM, NS, ZE, PS, PM, PB which stands for negative big, negative medium, negative small, zero positive small, positive medium, positive

big respectively. For simplicity it is assumed that the membership functions are symmetrical and each one overlaps the adjacent functions by 50% i.e., triangle shaped function, the other type of functions used are trapezoidal-shaped and Bell-shaped. Figure 3.2 shows the seven linguistic variable and the triangular membership function with 50% overlap and the universe of discourse from $-a$ to a .

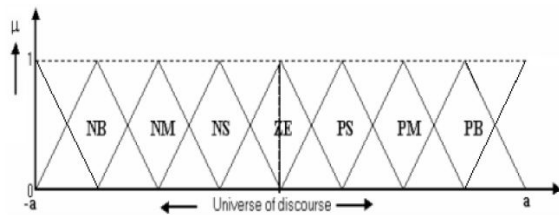

Fig.2. Triangular Membership Functions

2. Knowledge Base (KB) Knowledge base comprises of the definitions of fuzzy MFs for the input and output variables and the necessary control rules, which specify the control action by using linguistic terms. It consists of a database and linguistic control rule base.

- The database provides necessary definitions, which are used to define linguistic control rules and fuzzy data, manipulation in a FLC.
- The rule base characterizes the control goals and control policy of the domain experts by means of a set of a set of linguistic control rules.

3. Inference Mechanism

The Decision-Making Logic Which plays an essential role and contains a set of fuzzy if-then rules such as IF x is A and y is B then z is C Where x , y and z are linguistic variables representing two input variables and one control output: A , B and C are linguistic values. It is kernel of an FLC, it has the capability of simulating human decision making based on fuzzy control actions employing fuzzy implication and the rules of inference in fuzzy

logic. In general, fuzzy systems map input fuzzy sets to output fuzzy sets, fuzzy rules are the relation between input/output fuzzy sets. They are usually in the form if A . (set of conditions are satisfied) then B , (set of consequences can be inferred). Each rule defines a fuzzy path in the Cartesian product $A \times B$ (system state space). The antecedents of each fuzzy rule describe a fuzzy input region in the state space. For a system of two-control variable with seven linguistic variables in each range, this leads to a 7×7 decision table. The knowledge required to generate the fuzzy rules can be derived from an off – line simulation, an expert operator and/or a design engineer. Some knowledge can be used on the understanding of the dynamic system under control. A lot of effort has been devoted to the creation of the fuzzy rules. Normally rule definition is based on the operator’s experience and the engineer’s knowledge. However, it has been noticed in practice that for monotonic systems a symmetrical rule table is very appropriate, although sometimes it may need slight adjustment based on behavior of the specific system. If the system dynamics are not known or if the system is highly non – linear, trial and error procedure and experience play an important role in defining the rules.

4. Defuzzification

Defuzzification converts the linguistic variables to determine numerical values. Centroid method of defuzzification is used in this study.

- A scale mapping, which converts the range of values of input variables into corresponding universe of discourse.
- Defuzzification, which yields a non-fuzzy control action from an inferred fuzzy control action.

We defuzzify the output distribution B to produce a single numerical output, a single

value in the output universe of discourse $Y = \{y_1, y_2, \dots, y_p\}$. The information in the output waveform B resides largely in the relative values of membership degrees. The simplest defuzzification scheme chooses that, element Y_{max} . That has maximal membership put in the output fuzzy set B . $M_B(y_{max}) = \max_{1 \leq j \leq k} m_B(y_j)$. The maximum membership defuzzification scheme has two fundamental problems. First, the mode of the B distribution is not unique. In practice B is often highly asymmetric; even if it is unimodal infinitely many output distributions can share the same mode. The maximum membership scheme ignores the information in much of the waveform B . The natural alternative is the fuzzy centroid defuzzification scheme. The regions in which the control actions are overlapped depending upon their membership function. The area thus obtained is divided into narrow strips of equal width of each vertical line, the membership function and the corresponding point on the universe of discourse is evaluated. The centroid is calculated using the formula given below. The graphical representation of centroid is shown in Fig. below. $B = \sum_{j=1}^p \mu_B(y_j) / \sum_{j=1}^p \mu_B(y_j)$ 5.5 Where $m_B(y_j) =$ membership function of the j th strip. $y_j =$ Corresponding Crisp value of j th strip. $p =$ number of strips.

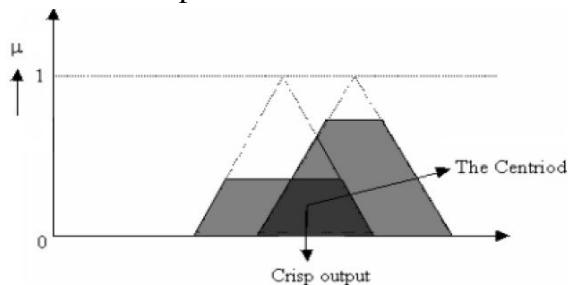

Fig.3. A Graphical Representation of Centroid

This value is actually the deterministic input required to regulate the process. The entire

universe of discourse is then divided into seven triangles, equal in area, each representing the region of the linguistic variables as in fuzzification. The fuzzy centroid is unique and uses all the information in the output distribution B . Computing the centroid is only step in the defuzzification process, which requires simple division.

III. PROPOSED DUAL VOLTAGE SOURCE INVERTER

A. System Topology

The proposed DVSI topology is shown in Fig. It consists of a neutral point clamped (NPC) inverter to realize AVSI and a three-leg inverter for MVSII [13]. These are connected to grid at the PCC and supplying a nonlinear and unbalanced load. The function of the AVSI is to compensate the reactive, harmonics, and unbalance components in load currents. Here, load currents in three phases are represented by i_{la} , i_{lb} , and i_{lc} , respectively. Also, $i_{g}(abc)$, $i_{\mu gm}(abc)$, and $i_{\mu gx}(abc)$ show grid currents, MVSII currents, and AVSI currents in three phases, respectively. The dc link of the AVSI utilizes a split capacitor topology, with two capacitors C_1 and C_2 . The MVSII delivers the available power at distributed energy resource (DER) to grid. The DER can be a dc source or an ac source with rectifier coupled to dc link. Usually, renewable energy sources like fuel cell and PV generate power at variable low dc voltage, while the variable speed wind turbines generate power at variable ac voltage. Therefore, the power generated from these sources use a power conditioning stage before it is connected to the input of MVSII. In this study, DER is being represented as a dc source. An inductor filter is used to eliminate the high-frequency switching components generated due to the switching of power electronic switches in

the inverters. The system considered in this study is assumed to have some amount of feeder resistance R_g and inductance L_g . Due to the presence of this feeder impedance, PCC voltage is affected with harmonics. Section III describes the extraction of fundamental positive sequence of PCC voltages and control strategy for the reference current generation of two inverters in DVSI scheme.

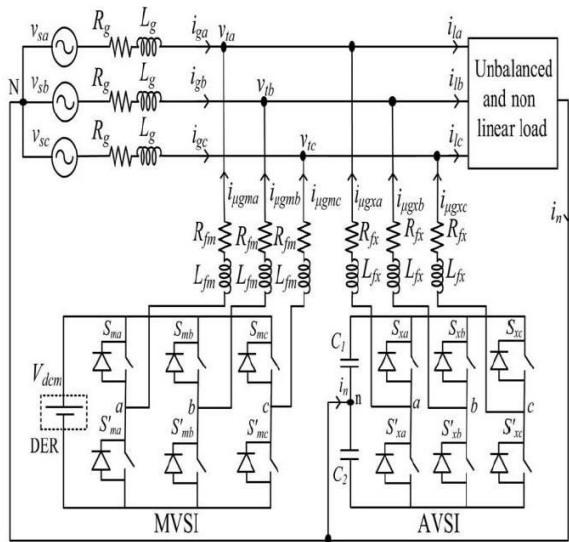

Fig.4. Topology of Proposed DVSI Scheme.

B. Design of DVSI Parameters

1. AVSI

The important parameters of AVSI like dc-link voltage (V_{dc}), dc storage capacitors ($C1$ and $C2$), interfacing inductance (L_{fx}), and hysteresis band ($\pm h_x$) are selected based on the design method of split capacitor DSTATCOM topology [16]. The dc-link voltage across each capacitor is taken as 1.6 times the peak of phase voltage. The total dc-link voltage reference (V_{dcref}) is found to be 1040 V. Values of dc capacitors of AVSI are chosen based on the change in dc-link voltage during transients. Let total load rating is S kVA. In the worst case, the load power may vary from minimum to maximum, i.e., from 0 to S kVA. AVSI needs to

exchange real power during transient to maintain the load power demand. This transfer

of real power during the transient will result in deviation of capacitor voltage from its reference value. Assume that the voltage controller takes n cycles, i.e., nT seconds to act, where T is the system time period. Hence, maximum energy exchange by AVSI during transient will be $benST$. This energy will be equal to change in the capacitor stored energy. Therefore

$$\frac{1}{2}C_1(V_{dcr}^2 - V_{dc1}^2) = nST \quad (1)$$

where V_{dcr} and V_{dc1} are the reference dc voltage and maximum permissible dc voltage across $C1$ during transient, respectively. Here, $S = 5$ kVA, $V_{dcr} = 520$ V, $V_{dc1} = 0.8$, V_{dcr} or 1.2 , V_{dcr} , $n=1$, and $T= 0.02$ s. Substituting these values in (1), the dclink capacitance ($C1$) is calculated to be 2000 μ F. Same value of capacitance is selected for $C2$. The interfacing inductance is given by

$$L_{fx} = \frac{1.6 V_m}{4 h_x f_{max}} \quad (2)$$

Assuming a maximum switching frequency (f_{max}) of 10 kHz and hysteresis band (h_x) as 5% of load current (0.5 A), the value of L_{fx} is calculated to be 26 mH. **2. MVSI** The MVSI uses a three-leg inverter topology. Its dc-link voltage is obtained as $1.15 * V_{ml}$, where V_{ml} is the peak value of line voltage. This is calculated to be 648 V. Also, MVSI supplies a balanced sinusoidal current at unity power factor. So, zero sequence switching harmonics will be absent in the output current of MVSI. This reduces the filter requirement for MVSI as compared to AVSI. In this analysis, a filter inductance (L_{fm}) of 5 mH is used.

IV. CONTROL STRATEGY FOR DVSI SCHEME

A. Fundamental Voltage Extraction

The control algorithm for reference current generation using ISCT requires balanced sinusoidal PCC voltages. Because of the presence of feeder impedance, PCC voltages are distorted. Therefore, the fundamental positive sequence components of the PCC voltages are extracted for the reference current generation. To convert the distorted PCC voltages to balanced sinusoidal voltages, $dq0$ transformation is used. The PCC voltages in natural reference frame (v_{ta} , v_{tb} , and v_{tc}) are first transformed into $dq0$ reference frame as given by

$$\begin{bmatrix} v_{td} \\ v_{tq} \\ v_{t0} \end{bmatrix} = C \begin{bmatrix} v_{ta} \\ v_{tb} \\ v_{tc} \end{bmatrix}$$

where

$$C = \sqrt{\frac{2}{3}} \begin{bmatrix} \sin \theta & \sin(\theta - \frac{2\pi}{3}) & \sin(\theta + \frac{2\pi}{3}) \\ \cos \theta & \cos(\theta - \frac{2\pi}{3}) & \cos(\theta + \frac{2\pi}{3}) \\ \frac{1}{\sqrt{2}} & \frac{1}{\sqrt{2}} & \frac{1}{\sqrt{2}} \end{bmatrix} \quad (3)$$

In order to get θ , a modified synchronous reference frame (SRF) phase locked loop (PLL) [23] is used.

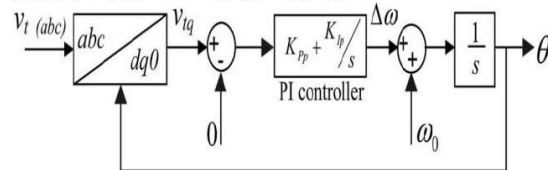

Fig.5. Schematic Diagram of PLL.

The schematic diagram of this PLL is shown in Fig. It mainly consists of a proportional integral (PI) controller and an integrator. In this PLL, the SRF terminal voltage in q -axis (v_{tq}) is compared with 0 V and the error voltage thus obtained is given to the PI controller. The frequency deviation $\Delta\omega$ is then added to the reference frequency ω_0 and finally given to the integrator to get θ . It can be proved that, when, $\theta = \omega_0 t$ and by using the Park's transformation matrix (C), q -axis voltage in $dq0$ frame becomes

zero and hence the PLL will be locked to the reference frequency (ω_0).

B. Instantaneous Symmetrical Component Theory

ISCT was developed primarily for unbalanced and nonlinear load compensations by active power filters. The system topology shown in Fig is used for realizing the reference current for the compensator. The ISCT for load compensation is derived based on the following three conditions

- The source neutral current must be zero. Therefore

$$i_{sa} + i_{sb} + i_{sc} = 0. \quad (4)$$

- The phase angle between the fundamental positive sequence voltage (v_{ta1}) and source current (i_{sa}) is ϕ
- The average real power of the load (P_l) should be supplied by the source

$$v_{ta1}^+ i_{sa} + v_{tb1}^+ i_{sb} + v_{tc1}^+ i_{sc} = P_l. \quad (6)$$

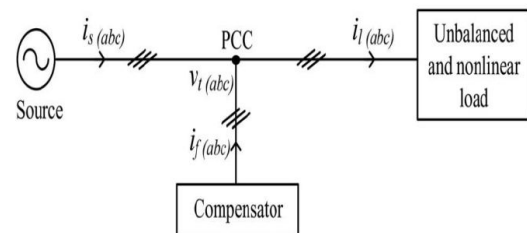

Fig.6. Schematic of an Unbalance and Nonlinear Load Compensation Scheme.

Solving the above three equations, the reference source currents can be obtained as

$$i_{sa}^* = \left(\frac{v_{ta1}^+ + \beta(v_{tb1}^+ - v_{tc1}^+)}{\sum_{j=a,b,c} v_{tj}^{+2}} \right) P_l \quad (7)$$

$$i_{sb}^* = \left(\frac{v_{tb1}^+ + \beta(v_{tc1}^+ - v_{ta1}^+)}{\sum_{j=a,b,c} v_{tj}^{+2}} \right) P_l \quad (8)$$

$$i_{sc}^* = \left(\frac{v_{tc1}^+ + \beta(v_{ta1}^+ - v_{tb1}^+)}{\sum_{j=a,b,c} v_{tj}^{+2}} \right) P_l \quad (9)$$

A modification in the control algorithm is required, when it is used for DVSI scheme. The following section discusses the formulation of

control algorithm for DVSI scheme. The source currents, $i_s(abc)$ and filter currents $i_f(abc)$ will be equivalently represented as grid currents $i_g(abc)$ and AVSI currents $i_{ugx}(abc)$, respectively, in further sections.

V. SIMULATION RESULTS

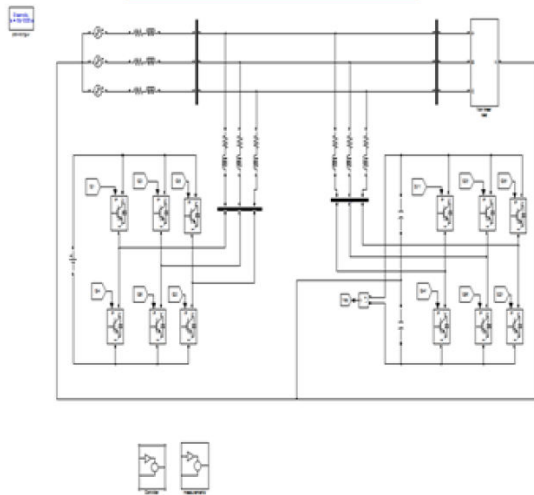

Fig.7. Matlab/Simulink Diagram of Proposed DVSI System

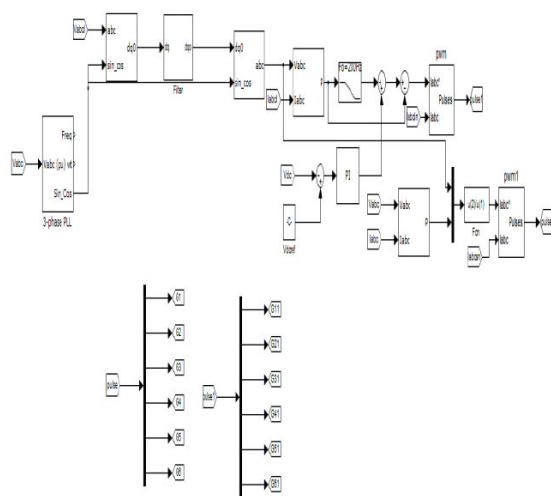

Fig.8. Controller Subsystem.



Fig.9. Load Active Power.

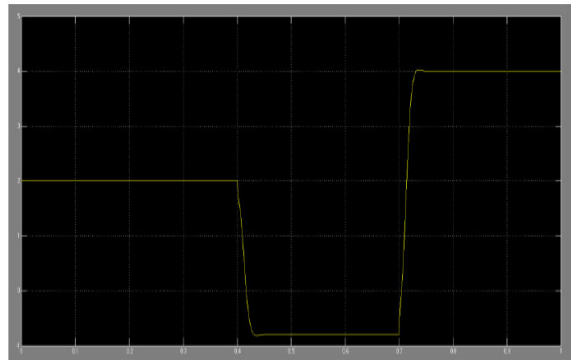

Fig.10. Active Power Supplied by Grid.

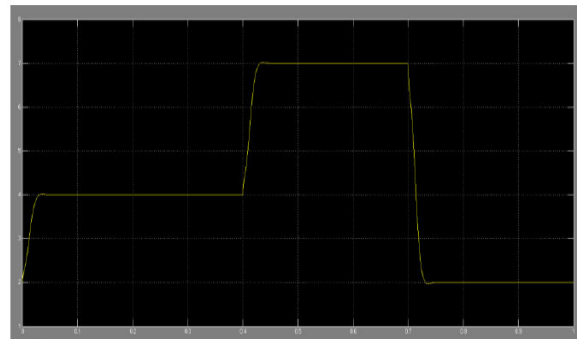

Fig.11. Active Power Supplied by MVSI.

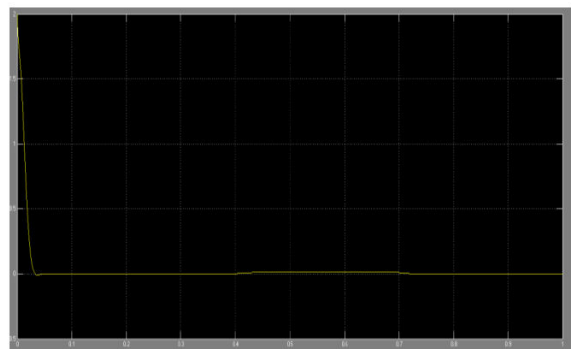

Fig.12. Active Power Supplied by AVSI.

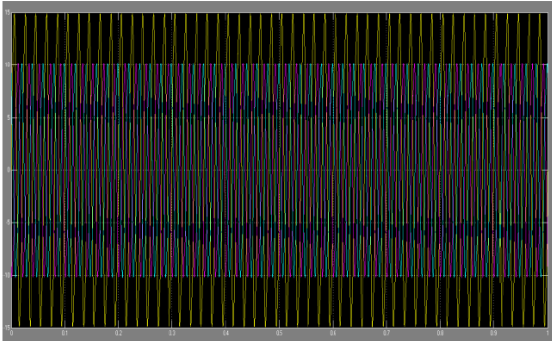

Fig.13. Load Currents.

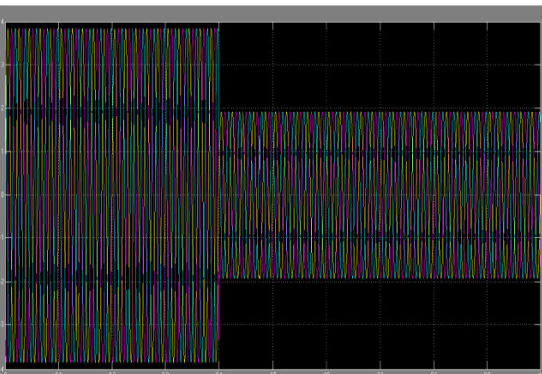

Fig.14. Grid Currents.

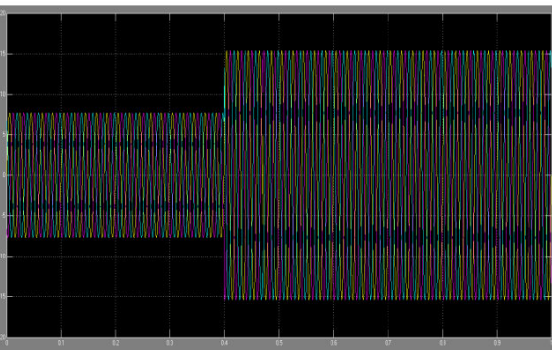

Fig.15. MVSI Currents.

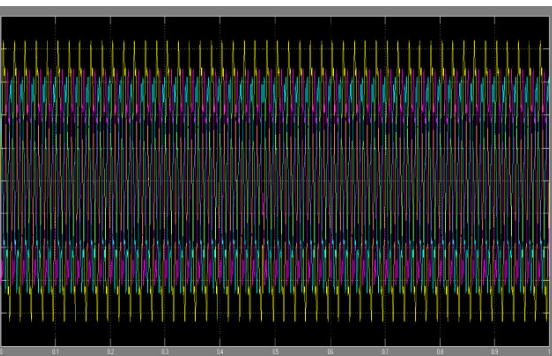

Fig.16. AVSI Currents.

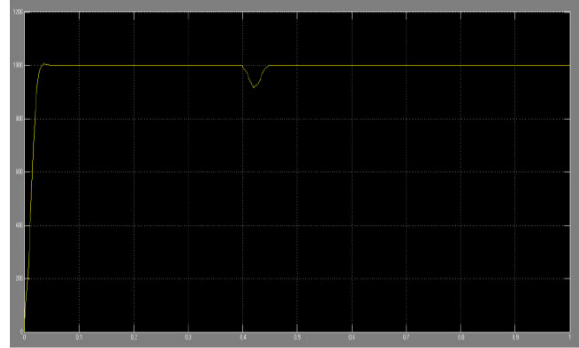

Fig.17. DC Link Voltage.

VI. CONCLUSION The proposed DVSI is Control algorithms are developed to generate reference currents for DVSI using ISCT. The proposed scheme has the capability to exchange power from distributed generators (DGs) and also to compensate the local unbalanced and nonlinear load. The performance of the proposed scheme has been validated through simulation and experimental studies. As compared to a single inverter with multifunctional capabilities, a DVSI has many advantages such as, increased reliability, lower cost due to the reduction in filter size, and more utilization of inverter capacity to inject real power from DGs to microgrid. Moreover, the use of three-phase, threewire topology for the main inverter reduces the dc-link voltage requirement. Thus, a DVSI scheme is a suitable interfacing option for microgrid supplying sensitive loads. Simulation results are observed for a proposed fuzzy based DVSI.

REFERENCES

- [1]Y. Zhang, N. Gatsis, and G. Giannakis, —Robust energy management for microgrids with high-penetration renewables,| IEEE Trans. Sustain.Energy, vol. 4, no. 4, pp. 944–953, Oct. 2013. [2]R. Majumder, A. Ghosh, G. Ledwich, and F. Zare, —Load sharing and power quality enhanced operation of a distributed microgrid,| IET Renewable Power Gener., vol. 3, no. 2, pp. 109–119, Jun. 2009. [3]J. Guerrero, P. C. Loh,



T.-L. Lee, and M. Chandorkar, —Advanced control architectures for intelligent microgrids— Part II: Power quality, energy storage, and ac/dc microgrids,|| IEEE Trans. Ind. Electron., vol. 60, no. 4, pp. 1263–1270, Dec. 2013. [4]Y. Li, D. Vilathgamuwa, and P. C. Loh, —Microgrid power quality enhancement using a three-phase four-wire grid-interfacing compensator,|| IEEE Trans. Ind. Appl., vol. 41, no. 6, pp. 1707–1719, Nov. 2005. [5]M. Schonardie, R. Coelho, R. Schweitzer, and D. Martins, —Control of the active and reactive power using dq0 transformation in a three-phase grid-connected PV system,|| in Proc. IEEE Int. Symp. Ind. Electron., May 2012, pp. 264–269. [6]R. S. Bajpai and R. Gupta, —Voltage and power flow control of grid connected wind generation system using DSTATCOM,|| in Proc. IEEE Power Energy Soc. Gen. Meeting—Convers. Del. Elect. Energy 21st Century, Jul. 2008, pp. 1–6. [7]M. Singh, V. Khadkikar, A. Chandra, and R. Varma, —Grid interconnection of renewable energy sources at the distribution level with power-quality improvement features,|| IEEE Trans. Power Del., vol. 26, no. 1, pp. 307–315, Jan. 2011. [8]H.-G. Yeh, D. Gayme, and S. Low, —Adaptive VAR control for distribution circuits with photovoltaic generators,|| IEEE Trans. Power Syst., vol. 27, no. 3, pp. 1656–1663, Aug. 2012. [9]C. Demoulias, —A new simple analytical method for calculating the optimum inverter size in grid-connected PV plants,||Electr. Power Syst. Res., vol. 80, no. 10, pp. 1197–1204, 2010. [10]R. Tonkoski, D. Turcotte, and T. H. M. EL-Fouly, —Impact of high PV penetration on voltage profiles in residential neighborhoods,|| IEEE Trans. Sustain. Energy, vol. 3, no. 3, pp. 518–527, Jul. 2012. [11]P. Rodriguez et al., —A stationary reference frame grid synchronization system for three-

phase grid-connected power converters under adverse grid conditions,||IEEE Trans. Power Electron., vol. 27, no. 1, pp. 99–112, Jan. 2012. [12]S. Iyer, A. Ghosh, and A. Joshi, —Inverter topologies for DSTATCOM applications—A simulation study,||Electr. Power Syst. Res., vol. 75, no. 23, pp. 161–170, 2005. [13]Y. Tang, P. C. Loh, P. Wang, F. H. Choo, and F. Gao, —Exploring inherent damping characteristic of LCL filters for three-phase grid-connected voltage source inverters,|| IEEE Trans. Power Electron., vol. 27, no. 3, pp. 1433–1443, Mar. 2012.