



COPY RIGHT



ELSEVIER

SSRN

2020 IJIEMR. Personal use of this material is permitted. Permission from IJIEMR must be obtained for all other uses, in any current or future media, including reprinting/republishing this material for advertising or promotional purposes, creating new collective works, for resale or redistribution to servers or lists, or reuse of any copyrighted component of this work in other works. No Reprint should be done to this paper, all copy right is authenticated to Paper Authors

IJIEMR Transactions, online available on 06th Sep 2020. Link

[:http://www.ijiemr.org/downloads.php?vol=Volume-09&issue=Issue09](http://www.ijiemr.org/downloads.php?vol=Volume-09&issue=Issue09)

10.48047/IJIEMR/V09/ISSUE 09/41

TITLE: A WIRELESS power transfer topology for EV battery charger

Volume 09, ISSUE 09, Pages: 285-294

Paper Authors B. Mabu Sarif1, Shambuni VineethKumar2, Kandakatla Karthik2, Badugu Rahul2, Guduru Sai Shiva2



USE THIS BARCODE TO ACCESS YOUR ONLINE PAPER

To Secure Your Paper As Per **UGC Guidelines** We Are Providing A Electronic Bar Code

A WIRELESS power transfer topology for EV battery charger

B. Mabu Sarif¹, Shambuni VineethKumar², Kandakatla Karthik², Badugu Rahul², Guduru Sai Shiva²

¹Assistant professor,²UG Student, Department of Electrical and Electronics Engineering

^{1,2}Malla Reddy Engineering College and Management Sciences, Kistapur, Medchal-501401, Hyderabad, Telangana, India

Abstract:

Usually, electric vehicle systems are supported various modules that ought to make sure the high power and stability of the vehicle on the track. The bulk of those components are linked to the charging mechanism. During this regard, dynamic wireless power transfer is a practical method to resolve electric vehicle range anxiety and reduce the price of onboard batteries. The foremost problem of EV industry is, Battery charging facility, however battery charging problem is still a challenging task for EV industry. In this article, A classical series L-C compensation methodology is proposed. The proposed method is verified by using MATLAB based simulations for pure resistive load. Finally, The results of proposed system is obtained by using MATLAB based simulations rated for 18.702kHz Resonance (switching) frequency. We obtained 48.09V DC output voltage for EV battery charging and 0.48A current range. Therefore, we can transfer A full dynamic power is 23.08W.

Keywords: DC/HFAC Inverter, EV Battery, Wireless Power Transmission System, Series Compensation

1. INTRODUCTION

The transport sector accounts for 18% of total energy consumption in India. This translates to an estimated 94 million tons of oil equivalent (MTOE) energy. If India were to follow this trends of energy consumption, it'd require an estimated 200 MTOE of energy supply annually, by the year 2030 to fulfilled the demand of this sector.[1] Wireless power transfer (WPT), or electromagnetic power transfer is that the transmission of electrical energy without wires as a physical link. In every wireless power transmission gear mechanism, a transmitter device, driven by wattage from a power source, generates a time-varying electromagnetic field, which transmits power across space to a receiver device, which extracts power from the magnetic flux and sending it to an electrical application. The technology of wireless power transmission can eliminate the employment of the wires and batteries, thus increasing the mobility, convenience, and safety of an device for all users.[2] Wireless power transfer is helpful to power electrical devices where interconnecting wires are inconvenient, hazardous are not possible. Wireless power transfer topology mainly classified into two categories, closed to field and far field. In closed to field techniques, power is transferred over short distances by magnetic fields using inductive coupling between coils of wires, or by electric flux using captive coupling between metal electrodes.[3],[4],[5],[6]. Within the past, battery technology is that the major problem in EV industry to place EV out of market

success. But, now battery technology has been rapidly developed with good performance. In present scenario efficient, fast charging technology has been implemented. The major problem of EV industry is, Battery charging facility. Therefore, to avoid this problem, efficient wireless power transfer topology is adopted for EV battery charging during stationary & dynamic mode of EV.

In this article, A classical series L-C compensation methodology is utilized for efficient wireless power transfer for EV battery charging. The proposed methodology offers constant output voltage, if input voltage get variable without any kind auxiliary equipment's.

The rest of the article is categorized to following sections. The general configuration of proposed system is discussed in section II. The simulation modelling of proposed system is discussed in section III. Designed Circuit parameter is

presented in section IV. Section V discussed with simulation results and discussion. Finally, Conclusion has been discussed in section VI.

THE GENERAL CONFIGURATION OF WPT SYSTEM

In below figure, the general configuration of wireless power transfer system is discussed. In this system consist of two main parts. 1) Under the road (on the road structure), 2) In the vehicle (Equipped vehicle structure). The fixed part which is called as transmitter is placed under the road, and the moving part which is called as receiver is placed in the vehicle body. A vacuum separates the two parts and each parts has its own electronic system. The transmitter section generates an alternating magnetic flux at high frequency. Then this magnetic flux gets linked with the receiver coil. Then, According to Faraday's laws of electromagnetic induction, Emf get induced in secondary coil. i.e. receiver coil. Then induced emf is used to charge the EV Battery. The transmitter section is placed under the road infrastructure, and it's connected to the series of electronic equipment's which is most important for wireless power transfer system.

Figure 1: General configuration of WPT system.

From fig. A nominal power is connected to the active front converter i.e., AC/DC converter, that provides a DC power supply. Then, this power supply is given to the high frequency full-bridge inverter which is controlling by modified pulse with modulation (MPWM), then this inverter converts input DC to high frequency AC power, which is deliver to transmitter coil. Then this magnetic flux gets linked with the receiver coil. Then, According to Faraday's laws of electromagnetic induction, Emf get induced in secondary coil. i.e., receiver coil. Then induced emf is used to charge the EV Battery.

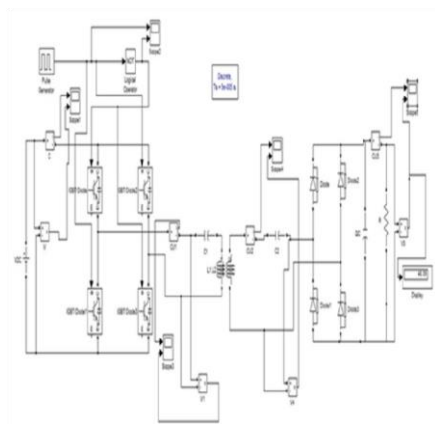
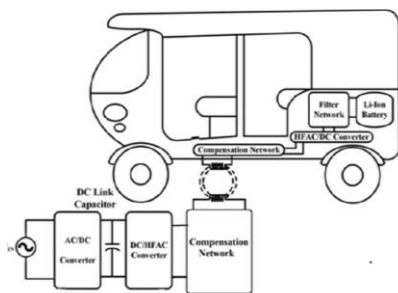

Figure 1: Simulation modelling of proposed WPT system.

CIRCUIT DESIGN PARAMETERS

- A. The Resonance frequency is calculated by using following equation. $f_r = 1 / 2 \pi \sqrt{LC}$.
- B. For calculating resonance frequency, we required two important parameters.

1. Compensated inductance.
2. Compensation capacitance.

Therefore, we can calculate the value of compensated inductance by using following equation. $(L) = NR\mu_0\mu_r [\ln (8R/r)^2]$

We took the value of compensation capacitance, according to selected applications.

C. The value of coefficient of coupling (k), is calculate by using following formula. $M = K \sqrt{L1 \times L2}$

$$K = M \div \sqrt{L1 \times L2}$$

L1: Self-inductance of coil 1
L2: Self-inductance of coil 2

D. The value of Mutual inductance is calculate by using following formula. $M = K \sqrt{L1 \times L2}$

E. Selected Electric Vehicles

Details. Name: - Mahindra TREO

(E-Rickshaw). Seating capacity: -

D + 4 Seaters. Battery details: - 1.

Li-ion type.

2. 48V voltage

range 3. 76.87 Ah

Battery installed capacity: - 3.69

Kwhr. Electric Motor: - BLDC

motor, 1 HP. Ground Clearance:

- 142 mm

Top Speed: - 24.5 km/hr

Transmission: - Direct

Drive. Peak Torque: - 22

NM

Peak Power: - 1.95Kw

We designed all parameters for above Electric Vehicle applications.

Table 1: Design Parameters for Matlab Simulations

Sr. No.	PARAMETERS	SYMBOL	DETAILS
01	Input DC voltage	V	395 V
02	Resonant (Switching) frequency	Fr	18.702 KHZ
03	Primary coil inductance	L1	362.1 uH
04	Secondary coil inductance	L2	362.1 uH

05	Primary coil series resistance	R1	0.04108 ohm
06	Secondary coil series resistance	R2	0.04108 ohm
07	Coefficient of coupling	Kc	0.2
08	Compensation capacitor of primary coil	C1	0.2 uF
09	Compensation capacitor of secondary coil	C2	0.2 uF
10	Battery type	Li-ion	Li-ion
12	Load resistance	RL	100 ohm
13	Internal resistance of diode	RON	0.001 ohm
14	Diode forward voltage	VF	0.8 V
15	Internal inductance of diode	H	0 H
16	Filter capacitance	Cf	0.005 F
17	Pulse duty cycle	%	50

I. RESULTS AND DISCUSSION

The operating principle of the proposed wireless power transfer methodology is validated by performing on MATLAB based modelling and simulation. The simulation results of proposed wireless power transfer system are as following. The results are divided into five cases as following.

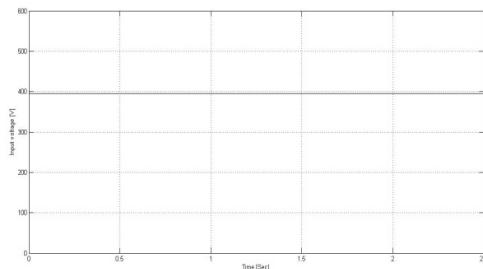

Case 1: Input DC voltage

Figure 3 shows that, the input 395V DC is applied to high frequency converter for DC/HFAC conversion. **Case 2: Gate Pulses**

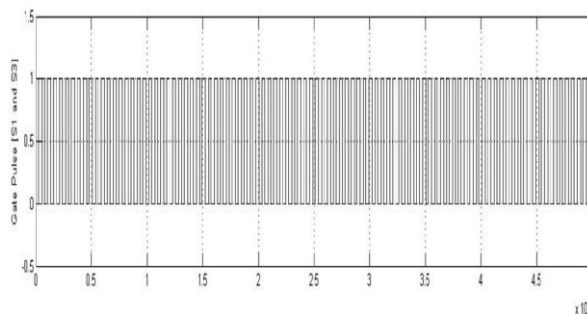

Figure 4 shows that the pulses applied to IGBT switch of HFAC converter from pulse generator and switch 1 & 3 are get turn On.

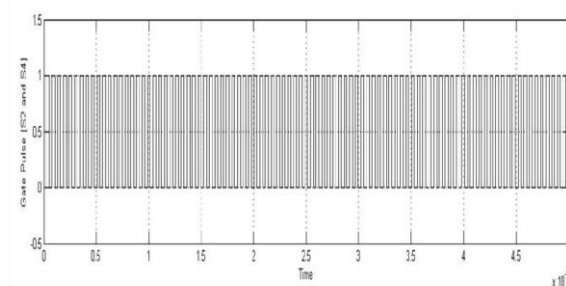

Figure 5 shows that, when pulses which is applied by pulse generator are get zero, then NOT logical operator is get invert that pulses and applied that pulses to IGBT switch of HFAC converter and switch 2 & 4 are get turn On In this way the DC/HFAC converter is control by using simple pulse width modulation technique.

Case 3: Output of DC/HFAC Converter.

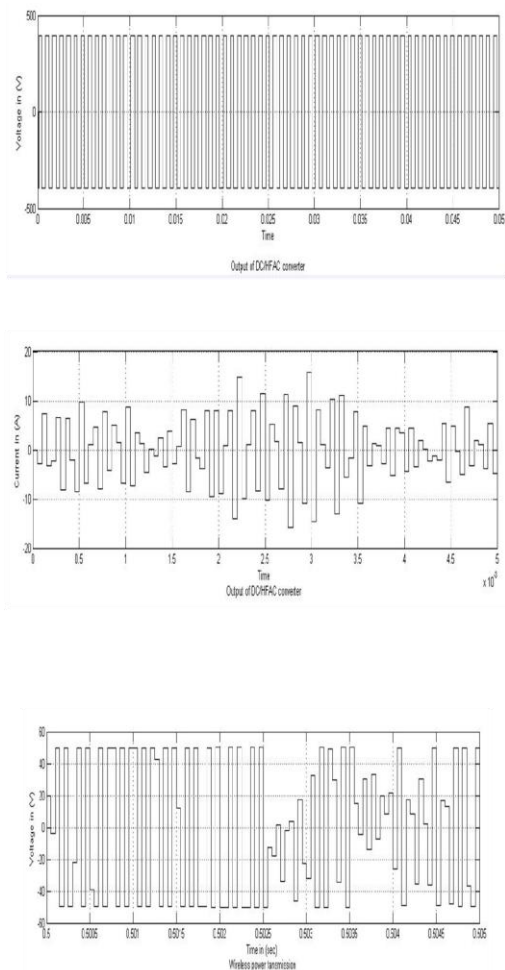

Figure 7 it indicates that the output current of DC/HFAC converter. According to above result, the value of current which is continuously varying converter due to change in flux linkage to the receiving coil.

Case 4: Wireless power transmission.

Figure 8 it indicates that, the wireless power transmission. In this case, due to mutual coupling of coils, change in fluxes of primary coil is get linked to secondary coil. Therefore, according to faradays laws of electromagnetic induction, EMF get induced in secondary coil. Hence, from above result we get 49V at output.

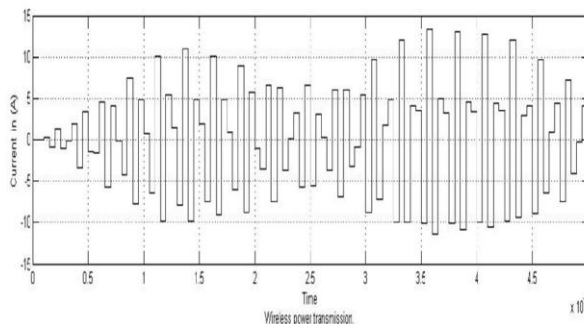

Figure 9 it indicates that, the value of output current. We get 4.2A current at output of secondary coil. **Case 5:** Output of bridge rectifier.

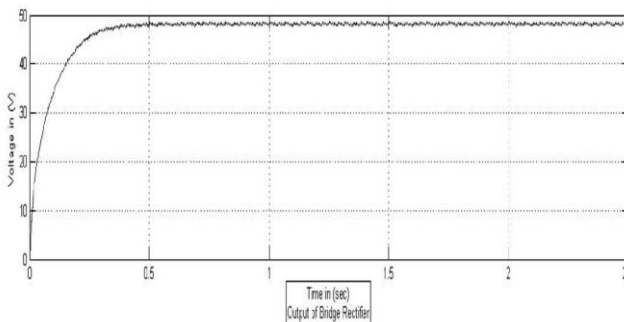

Figure10 it indicates that, the output of bridge rectifier for voltage quantity. It converts input 49V AC to 48.09V DC.

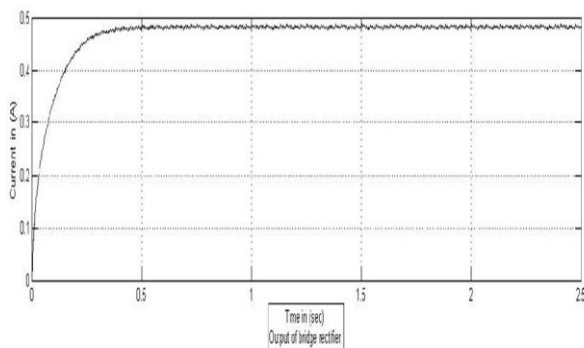

Figure11 it indicates that, the output of bridge rectifier for current quantity. Therefore, we get 0.48A current.

5. CONCLUSION

In this paper, A classical series L-C compensation methodology is proposed for wireless power

transfer for electric vehicle battery charging. We transfer efficient power through wireless without using of any kind of auxiliary equipment's. Therefore, by using this method, improving in simplicity of structure, operation and control system. And also, reduction in overall cost of the system. We know that, huge amount of power loss is takes place in wireless power transmission. At inductive and capacitive loads, the voltage and current quantities are not in phase, therefore power loss is more and we get minimum power at output. In this paper, we work on pure resistive load and high resonance frequency. Therefore, we get 94% of efficiency. In this way, the proposed technique is the best technique for the efficient wireless power transfer for electric vehicle (E.V.) battery charging.

REFERENCES

- [1]. Official Website of Bureau of Energy Efficiency, Ministry of power, Government of India.
- [2]. Ibrahim, F.N. Jamail, N.A.M. Othman, N.A. (2016). "Development of wireless electricity transmission through resonant coupling". 4th IET Clean Energy and Technology Conference (CEAT 2016).
- [3]. ECN Magazine. 27 October 2011. Retrieved 16 January 2015.
- [4]. Erfani, Reza; Marefat, Fatemeh; Sodagar, Amir M.; Mohseni, Pedram (2017). "Transcutaneous capacitive wireless power transfer (C-WPT) for biomedical implants". 2017 IEEE International Symposium on Circuits and Systems (ISCAS).
- [5]. Erfani, Reza; Marefat, Fatemeh; Sodagar, Amir M.; Mohseni, Pedram (May 2018). "Modeling and Characterization of Capacitive Elements With Tissue as Dielectric Material for Wireless Powering of Neural Implants". IEEE Transactions on Neural Systems and Rehabilitation Engineering. 26 (5): 1093–1099.
- [6]. Erfani, Reza; Marefat, Fatemeh; Sodagar, Amir M.; Mohseni, Pedram (July 2018). "Modeling and Experimental Validation of a Capacitive Link for Wireless Power Transfer to Biomedical Implants". IEEE Transactions on Circuits and Systems II: Express Briefs.
- [7]. Miguel Poveda-García; Jorge Oliva-Sanchez; Ramon Sanchez-Iborra; David Cañete-Rubenesque; Jose Luis Gomez-Tornero (2019).
- [8]. Bush, Stephen F. (2014). Smart grid communication-enabled intelligence for the electric power grid. John Wiley & Sons. p.
- [9]. Wireless energy transfer Encyclopaedia of terms. PC Magazine Ziff-Davis. 2014. Retrieved 15 December 2014.
- [10]. Marks, Paul (22 January 2014). Wireless charging for electric vehicles hits the road. New Scientist.
- [11]. Lu, Yan; Ki, Wing-Hung (2017). CMOS integrated circuit design for wireless power transfer. Springer.
- [12]. Sun, Tianjia; Xie, Xiang; Wang, Zhihua (2013). Wireless power transfer for medical microsystems. Springer Science and Business Media.
- [13]. Shin Y, Park J, Kim H, Woo S, Park B, Huh S, et al. Design Considerations for Adding Series Inductors to Reduce Electromagnetic Field Interference in an Over-Coupled WPT System. Energies 2021; 14:2791.
- [14]. Dai J, Ludois DC. Capacitive Power Transfer Through a Conformal Bumper for Electric Vehicle Charging.

IEEE J Emerg Sel Top Power Electron 2016; 4:1015–25.

[15]. Musavi F, Eberle W. Overview of wireless power transfer technologies for electric vehicle battery charging.

IET Power Electron 2014; 7:60–6.

[16]. S. B. Peterson, J. Whitacre, and J. Apt, “The economics of using plug-in hybrid electric vehicle battery packs for grid storage,” *J. Power Sources*, vol. 195, no. 8, pp. 2377–2384, 2010.

[17]. Y. Zhou, M. Wang, H. Hao, L. Johnson, and H. Wang, “Plug-in electric vehicle market penetration and incentives: A global review,” *Mitigation Adaptation Strategies Global Change*, vol. No.20

[18]. Y. Jiang, L. Wang, Y. Wang, J. Liu, X. Li, and G. Ning, “Analysis, design, and implementation of accurate ZVS angle control for EV battery charging in wireless high-power transfer,” *IEEE Trans. Ind. Electron.*, vol. 66, no. 5, pp. 4075–4085, May 2019.

[19]. D. H. Tran, V. B. Vu, and W. Choi, “Design of a high-efficiency wireless power transfer system with intermediate coils for the on-board chargers of electric vehicles,” *IEEE Trans. Power Electron.*, vol. 33, no. 1, pp. 175–187, Jan. 2018.