

DSTATCOM BASED INTELLIGENT FUZZY CONTROL TECHNIQUE IS USED FOR EXTERNAL INDUCTOR FOR VOLTAGE REGULATION

K SRINIVAS

Assistant Professor, Department of Electrical and Electronics Engineering, Siddhartha Institute of Technology and Sciences, Narapally, Hyderabad, Telangana, India

ABSTRACT—The paper intends to develop the fuzzy logic control of DSTATCOM for the improvement of power quality. The presence of nonlinear loads makes the voltage to be deviated and current to be distorted from its sinusoidal waveform quality. Thus harmonics elimination, load balancing and voltage regulation is the heavy task that has to be accomplished to maintain the quality of the power. The performance of any device depends on the control algorithm used for the reference current estimation and gating pulse generation scheme. The fuzzy logic based supervisor varies the proportional and integral gains of the PI controller during the transient period immediately after a load change. An improvement in the performance of the controller is obtained because of appropriate variation of PI gains using expert knowledge of system behavior and higher sampling during the transient period a DSTATCOM, which is one of the custom power devices, is used to control the terminal voltage. In a DSTATCOM, However, during load changes, there is considerable variation in dc capacitor voltage which might affect compensation. In this work, a fuzzy logic based supervisory method is proposed to improve transient performance of the dc link. In simulation study, the dynamic response of D-STATCOM is observed by changing the reference reactive current. A comparison of the simulation results between the proposed Fuzzy technique and the conventional PI controller has been presented. Simulation of Fuzzy-PI current controlled D-STATCOM is performed by MATLAB/Simulink software.

Keywords—Distribution Static Compensator (DSTATCOM), PI and Fuzzy Logic Controller, current control, voltage control, power factor, power quality.

I. INTRODUCTION

The concept of Flexible Ac Transmission (FACTS), as the name implies, was originally developed for transmission networks but similar ideas are applied to distribution systems. The new high power electronic systems applied to Distribution systems owe something to the ideas

of FACTS but also use concepts and techniques developed for power electronic systems with

lower voltage and current ratings. The major problem today the distribution system facing is power quality. The quality of power that is given to the end users is not up to the mark.

Because of this there is a failure in the devices. In order to overcome this problem that means to improve the quality of the power we are implementing certain devices in the transmission system. Power converter based custom power devices (CPDs) are useful for reduction of power quality problems such as

power factor correction, harmonics compensation, reduction in transients, voltage sag/swell compensation, resonance due to distortion, voltage flicker reduction within specified time and range. These CPDs include DSTATCOM, DVR and UPQC in different Configurations. Many non-model and training based alternative control algorithms are reported in the literature with application of soft computing technique such as neural network, fuzzy logic and adaptive neuro-fuzzy etc. A VSC based DSTATCOM has been introduced for better power quality improvement and thereby improving power factor correction and maintaining rated PCC voltage. For power quality improvement as power factor correction and to maintain rated PCC voltage a voltage source converter (VSC) based DSTATCOM has been preferred in the distribution systems. In this paper, Fuzzy-PI controller which is a robust controller is proposed for D-STATCOM's d and q-axes currents control. Models of power system, D-STATCOM, and controller unit are developed in MATLAB/Simulink environment. Two Fuzzy-PI are used for the control of d and q-axes currents separately. Inputs of Fuzzy-PI controllers are chosen as error values of d and q-axes currents and the change in these errors. Steady state error is eliminated by using the external integrator in outputs of Fuzzy-PI

controllers. Compared results of simulation with Fuzzy-PI controller and the linear PI with fixed parameters are given for the variations in reference reactive current. Utility distribution networks, sensitive industrial loads and critical commercial operations suffer from various types of outages and service interruptions which can

cost significant financial losses. With the restructuring of power systems and with shifting trend towards distributed and dispersed generation, the issue of power quality is going to take newer dimensions. This paper presents the Fuzzy Logic control of D-STATCOM to enhancement of harmonic distortion and low power factor using Distribution Static Compensator (D-STATCOM) with LCL Passive Filter in distribution system. Most of the control designs are carried out with linearized models. Nonlinear control strategies for D-STATCOM have also been reported recently-STATCOM controls for stabilization have been attempted through complex Lyapunov procedures for simple power system models. Recently, intelligent controllers like Fuzzy Logic Controllers (FLC) as alternative linear and nonlinear control techniques have been used in the control of D-STATCOM. Applications of fuzzy logic and neural network based controls have also been reported.

II. DSTATCOM IN POWER DISTRIBUTION SYSTEM

Fig.1 shows power circuit diagram of the DSTATCOM topology connected in distribution system. L_s and R_s are source inductance and resistance, respectively. An external inductance, L_{ext} is included in series between load and source points. This inductor helps DSTATCOM to achieve load voltage regulation capability even in worst grid conditions, i.e., resistive or

stiff grid. From IEEE-519 standard, point of common coupling (PCC) should be the point which is accessible to both the utility and the customer for direct measurement [20]. Therefore, the PCC is the point where L_{ext} is connected to the source. The DSTATCOM is connected at the point where load and L_{ext} are

connected. The DSTATCOM uses a three-phase four-wire VSI. A passive LC filter is connected in each phase to filter out high frequency switching components. Voltages across dc capacitors, V_{dc1} and V_{dc2} , are maintained at a reference value of V_{dcref} .

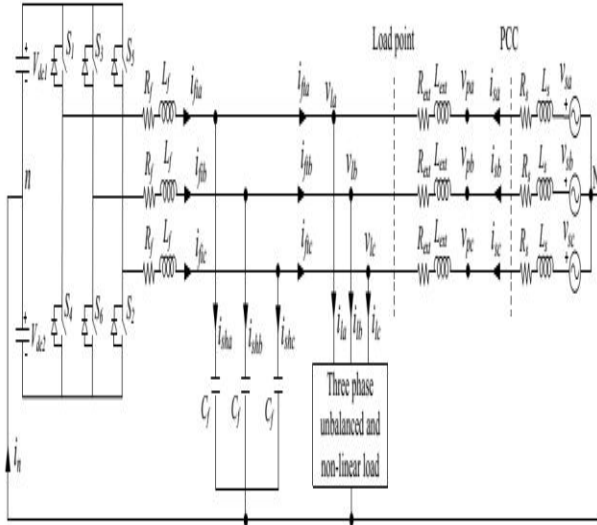

Fig.1. Three phase equivalent circuit of DSTATCOM topology in distribution system

III. EFFECT OF FEEDER IMPEDANCE ON VOLTAGE REGULATION

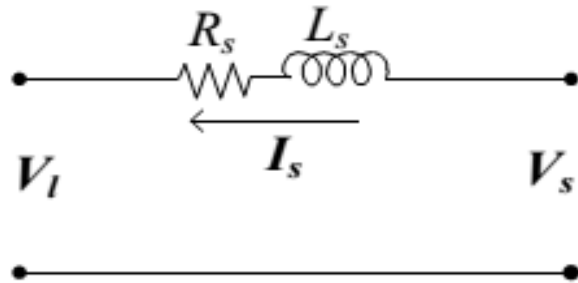

Fig.2. Equivalent source-load model without considering external inductor

To demonstrate the effect of feeder impedance on voltage regulation performance, an equivalent source-load model without considering external inductor is shown in Fig.2. The current in the circuit is given as

$$I_s = \frac{V_s - V_l}{Z_s} \quad (1)$$

where $V_s = V_s \angle \delta$, $V_l = V_l \angle 0$, $I_s = I_s \angle \phi$, and $Z_s = Z_s \angle \theta_s$, with V_s , V_l , I_s , Z_s , δ , ϕ , and θ_s are rms source voltage, rms load voltage, rms source current, feeder impedance, load angle, power factor angle, and feeder impedance angle, respectively. The three phase average load power (P_l) is expressed as

$$P_l = \text{Real} [3 V_l \times I_s^*] \quad (2)$$

Substituting V_l and I_s in (2), the load active power is

$$P_l = \frac{3V_l^2}{Z_s} \left[\frac{V_s}{V_l} \cos(\theta_s - \delta) - \cos \theta_s \right] \quad (3)$$

Rearranging (3), expression for δ is computed as follows:

$$\delta = \theta_s - \cos^{-1} \left[\frac{V_l}{V_s} \left(\cos \theta_s + \frac{P_l Z_s}{3 V_l^2} \right) \right] \quad (4)$$

For power transfer from source to load with stable operation in an inductive feeder, δ must be positive and less than 90° . Also, all the terms of the second part of (4), i.e., inside \cos^{-1} , are amplitude and will always be positive. Therefore, value of the second part will be between '0' to ' $\pi/2$ ' for the entire operation of the load. Consequently, the load angle will lie between θ_s to $(\theta_s - \pi/2)$ under any load operation, and therefore, maximum possible load angle is θ_s . The vector expression for source voltage is given as follows:

$$V_s = V_l + I_s Z_s \angle (\theta_s + \phi) \quad (5)$$

A DSTATCOM regulates the load voltage by injecting fundamental reactive current. To demonstrate the DSTATCOM voltage regulation capability at different supply voltages for different R_s/X_s ,

vector diagrams using (5) are drawn in Fig.3. To draw diagrams, load voltage V_l is taken as reference phasor having the nominal value OA (1.0 p.u.). With aim of making $V_l = V_s = 1.0$ p.u., locus of V_s will be a semicircle of radius V_l . Since, the maximum possible load angle is 90° in an inductive feeder, phasor V_s can be anywhere inside curve OACBO. It can be seen that the value of $\theta_s + \phi$ must be greater than 90° for zero voltage regulation. Additionally, it is possible only when power factor is leading at the load terminals θ_s cannot be more than 90° . Fig.3 (a) shows the limiting case when $R_s/X_s = 1$, i.e., $\theta_s = 45^\circ$. From (4), the maximum possible load angle is 45° . The maximum value of angle, $\theta_s + \phi$, can be 135° when ϕ is 90° . Hence, the limiting source current phasor OE, which is denoted by $I_{s\text{limit}}$, will lead the load voltage by 90° . Lines OC and AB show the limiting vectors of V_s and $I_s Z_s$, respectively with D as the intersection point. Hence, area under ACDA shows the operating region of DSTATCOM for voltage regulation. The point D has a limiting value of $V_{s\text{limit}} = I_s Z_s = 0.706$ p.u. Therefore, maximum possible voltage regulation is 29.4%. However, it is impossible to achieve these two limits simultaneously as δ and ϕ cannot be maximum at the same time. Again if Z_s is low then source current, which will be almost inductive, will be enough to be realized by a DSTATCOM. Fig.3 (b) considers case when $R_s/X_s = \sqrt{3}$ i.e., $\theta_s = 30^\circ$. The area under ACDA shrinks, which shows that with the

increase in R_s/X_s from the limiting value, the voltage regulation capability decreases. In this case the limiting values of $V_{s\text{limit}}$ and $I_s Z_s$ are found to be 0.866 and 0.5 p.u., respectively. Here, maximum possible voltage regulation is 13.4%. However, due to high current

requirement, a practical DSTATCOM can provide very small voltage regulation. Voltage regulation performance curves for more resistive grid, i.e., $\theta_s = 15^\circ$, as shown in Fig.3(c) can be drawn similarly. Here, area under ACDA is negligible. For this case, hardly any voltage regulation is possible. Therefore, more the feeder is resistive in nature, lesser will be the voltage regulation capability. Therefore, it is inferred that the voltage regulation capability of DSTATCOM in a distribution system mainly depends upon the feeder impedance. Due to resistive nature of feeder in a distribution system, DSTATCOM voltage regulation capability is limited. Moreover, very high current is required to mitigate small voltage disturbances which results in higher rating of IGBT switches as well as increased losses. One more point worth to be noted is that, in the resistive feeder, there will become voltage drop in the line at nominal source voltage which the DSTATCOM may not be able to compensate to maintain load voltage at 1.0 p.u. even with an ideal VSI.

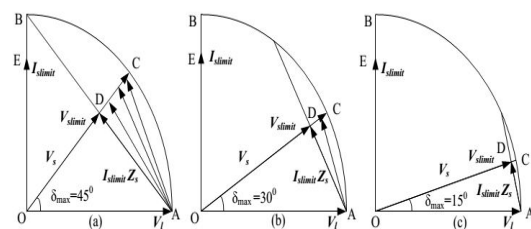

Fig.3. Voltage regulation performance curve of DSTATCOM at different R_s/X_s . (a) For $R_s/X_s = 1$. (b) For $R_s/X_s = \sqrt{3}$. (c) For $R_s/X_s = 3.73$.

IV. SELECTION OF EXTERNAL INDUCTOR FOR VOLTAGE REGULATION IMPROVEMENT AND RATING REDUCTION

A generalized procedure to select external inductor for improvement in DSTATCOM

voltage regulation capability while reducing the current rating of VSI. Fig.4 shows single phase equivalent DSTATCOM circuit diagram in distribution system. With balanced voltages, source current will be

$$I_s = \frac{V_s \angle \delta - V_l \angle 0}{(R_s + R_{ext}) + j(X_s + X_{ext})} = \frac{V_s \angle \delta - V_l \angle 0}{R_{sef} + jX_{sef}} \quad (6)$$

Where $R_{sef} = R_s + R_{ext}$ and $X_{sef} = X_s + X_{ext}$ are effective feeder resistance and reactance, respectively. R_{ext} is equivalent series resistance (ESR) of external inductor, and will be small. With an effective impedance angle and effective feeder impedance, respectively, the imaginary component of I_{si} is given as

$$\theta_{sef} = \tan^{-1} \frac{X_{sef}}{R_{sef}} \text{ and } Z_{sef} = \sqrt{R_{sef}^2 + X_{sef}^2}$$

$$I_s^{im} = \frac{V_l \sin \theta_{sef} + V_s \sin(\delta - \theta_{sef})}{Z_{sef}} \quad (7)$$

With the addition of external impedance, the effective feeder impedance becomes predominantly inductive. Hence, $Z_{sef} \approx X_{sef}$. Therefore, approximated I_s^{im} will be

$$I_s^{im} = \frac{V_l \sin \theta_{sef} + V_s \sin(\delta - \theta_{sef})}{X_{sef}} \quad (8)$$

DSTATCOM Power rating (S_{vsi}) is given as follows:

$$S_{vsi} = \sqrt{3} \frac{V_{dc}}{\sqrt{2}} I_{vsi} \quad (9)$$

Where I_{vsi} is the rms phase current rating of the VSI and V_{dc} is the voltage maintained at the dc capacitors. The DSTATCOM aims to inject harmonic and reactive current component of load currents. Suppose I_{lim} is the maximum rms reactive and harmonic current rating of the load,

then the value of compensator current used for voltage regulation (same as I_{sim}) is obtained by subtracting I_{lim} from I_{vsi} and given as follows:

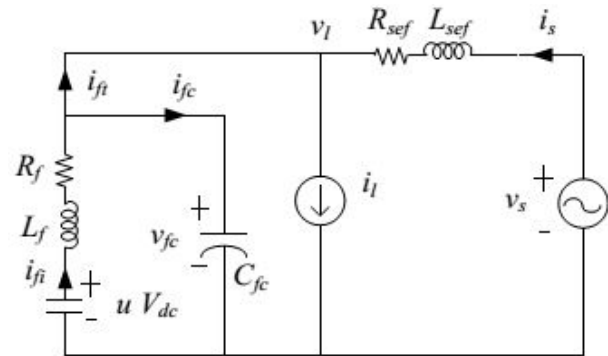

Fig.4. Single phase equivalent circuit of DSTATCOM topology with external inductor in distribution system

$$I = I_{vsi} - I_l^{im} = \frac{\sqrt{2} S_{vsi}}{\sqrt{3} V_{dc}} - I_l^{im} \quad (10)$$

Comparing (8) and (10) while using value of δ from (4), following expression is obtained:

$$X_{sef} = \frac{V_l \sin \theta_{sef} - V_s \sin \left[\cos^{-1} \left[\frac{V_l}{V_s} \left(\cos \theta_{sef} + \frac{P_l X_{sef}}{3 V_l^2} \right) \right] \right]}{\frac{\sqrt{2} S_{vsi}}{\sqrt{3} V_{dc}} - I_l^{im}} \quad (11)$$

V. DESIGN EXAMPLE OF EXTERNAL INDUCTOR

Here, it is assumed that the considered DSTATCOM protects load from voltage sag of 60%. Hence, source voltage $V_s = 0.6$ p.u. is considered as worst case voltage disturbances. During voltage disturbances, the loads should remain operational while improving the DSTATCOM capability to mitigate the sag.

Therefore, the load voltage during voltage sag is maintained at 0.9 p.u., which is sufficient for satisfactory operation of the load. In the present case, maximum required value of I_{lim} is 10 A. With the system parameters given in Table I, the effective reactance after solving (11) is found to

be 2.2Ω ($L_{sef} = 7$ mH). Hence, value of external inductance, L_{ext} , will be 6.7 mH. This external inductor is selected while satisfying the constraints such as maximum load power demand, rating of DSTATCOM, and amount of sag to be mitigated. In this design example, for base voltage and base power rating of 400V and 10 kVA, respectively, the value of external inductance is 0.13 p.u.

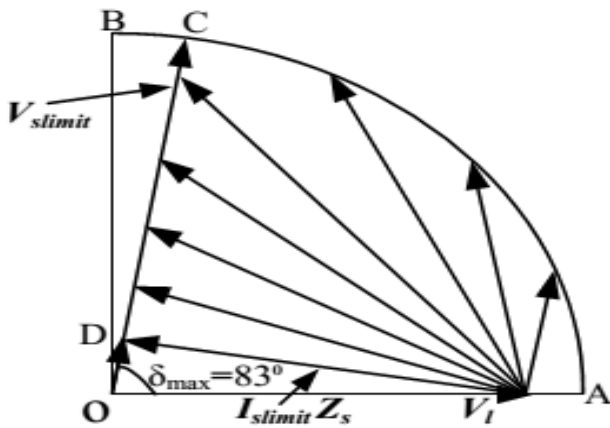

Fig.5. Voltage regulation performance of DSTATCOM with external inductance

Moreover, with total inductance of 7mH (external and actual grid inductance), the total impedance will be 0.137p. u. The short circuit capacity of the line will be $1/0.13 = 7.7$ p.u. Which is sufficient for the satisfactory operation of the system? Additionally, a designer always has flexibility to find suitable value of L_{ext} if the constraints are modified or circuit conditions are changed. Moreover, conventional STATCOM operated for achieving voltage regulation uses large feeder inductances.

With the external inductance while neglecting its ESR, R_s/X_{sef} will be 0.13 i.e., $\theta_{sef} = 83^\circ$. Voltage regulation performance curves of the DSTATCOM in this case are shown in Fig.5, where the area under ACDA covers the majority of the stable operating range OABO. Hence,

introduction of external inductor greatly improves the DSTATCOM voltage regulation capability. Additionally, due to increased effective feeder impedance the current requirement for sag mitigation also reduces. Moreover, if ESR of the external inductor is included, then the equivalent feeder impedance angle changes slightly (i.e., from 83 degree to 80.45 degree), and has negligible effect on the expression obtained in (11) as well as the voltage regulation capability of the DSTATCOM.

VI. FLEXIBLE CONTROL STRATEGY

A flexible control strategy to improve the performance of DSTATCOM in presence of the external inductor L_{ext} . Firstly, a dynamic reference load voltage based on the coordinated control of the load fundamental current, PCC voltage, and voltage across the external inductor is computed. Then, a proportional integral (PI) controller is used to control the load angle which helps in regulating the dc bus voltage at a reference value. Finally, three phase reference load voltages are generated. The block diagram of the control strategy is shown in Fig.6.

a) Derivation of Dynamic Reference Voltage Magnitude (V_l^*)

In conventional VCM operation of DSTATCOM, the reference load voltage is maintained at a constant value of 1.0p.u. [10]–[12]. Source currents cannot be controlled in this reference generation scheme. Therefore, power factor will not be unity and source

exchanges reactive power with the system even at nominal supply. To overcome this limitation, a flexible control strategy is developed to generate reference load voltage. This scheme allows DSTATCOM to set different reference

voltages during various operating conditions. The scheme is described in the following.

1) Normal Operation: It is defined as the condition when load voltage lies between 0.9 to 1.1 p.u. In this case, the proposed flexible control strategy controls load voltages such that the source currents are balanced sinusoidal and VSI does not exchange any reactive power with the source. Hence, the source supplies only fundamental positive sequence current component to support the average loads power and VSI losses. Reference source currents (i_{sj}^* where $j = a, b, c$ are three phases), computed using instantaneous symmetrical component theory, are given as

$$i_{sj}^* = \frac{v_{pj1}^+}{\Delta_1^+} (P_l + P_{loss}) \quad (12)$$

Where

$$\Delta_1^+ = \sum_{j=a,b,c} (v_{pj1}^+)^2$$

The voltages v_{pa1}^+ , v_{pb1}^+ and v_{pc1}^+ are fundamental positive sequence components of PCC voltages. Average load power (P_l) and VSI losses (P_{loss}) are calculated using moving average filter (MAF) as follows:

$$P_l = \frac{1}{T} \int_{t_1-T}^{t_1} (v_{la}i_{la} + v_{lb}i_{lb} + v_{lc}i_{lc}) dt \quad (13)$$

$$P_{loss} = \frac{1}{T} \int_{t_1-T}^{t_1} (v_{la}i_{fta} + v_{lb}i_{ftb} + v_{lc}i_{ftc}) dt \quad (14)$$

The reference source currents must be in phase with the respective phase fundamental positive sequence PCC voltages for achieving UPF at the

PCC. Instantaneous PCC voltage and reference source current in phase-a can be defined as follows:

$$v_{pa1}^+ = \sqrt{2}V_{pa1}^+ \sin(\omega t - \varphi_{pa1}^+), \quad i_{sa}^* = \sqrt{2}I_{sa}^* \sin(\omega t - \varphi_{pa1}^+) \quad (15)$$

Where V_{pa1}^+ and φ_{pa1}^+ are rms voltage and angle of fundamental positive sequence voltage in phase-a, respectively. I_{sa}^* is terms reference source current obtained from (12). With external impedance, the expected load voltage is given as follows:

$$V_{la} = V_{pa1}^+ - I_{sa}^* Z_{ext} \quad (16)$$

From (15) and (16), the load voltage magnitude will be

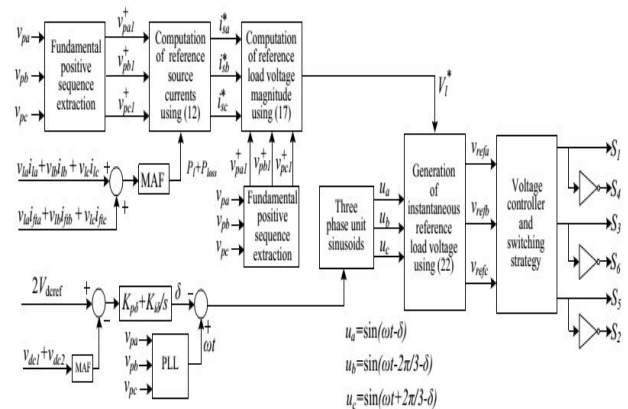

Fig.6. Block diagram of proposed flexible control strategy

$$V_{la} = \sqrt{\left[(V_{pa1}^+ \cos \varphi_{pa1}^+ - I_{sa}^* Z_{ext} \cos(\theta_{ext} - \varphi_{pa1}^+))^2 + (V_{pa1}^+ \sin \varphi_{pa1}^+ - I_{sa}^* Z_{ext} \sin(\theta_{ext} - \varphi_{pa1}^+))^2 \right]} \quad (17)$$

With UPF at the PCC, the voltage across the external inductor will lead the PCC voltage by 90°. Neglecting ESR of external inductor, it can be observed that the voltage across external inductor improves the load voltage compared to the PCC voltage. This highlights another advantage of external inductor where it helps in improving the load voltage. As long as V_{la} lies

between 0.9 to 1.1 p.u., same voltage is used as reference terminal voltage (V_l^*), i.e.

if $V_{la} \in [0.9 - 1.1 \text{ p.u.}]$, then $V_l^* = V_{la}$ (18)

2) **Operation during Sag:** Voltage sag is considered when value of (17) is less than 0.9 p.u. To keep filter current minimum, the reference voltage is set to 0.9 p.u. Therefore,

$$V_l^* = 0.9 \text{ p.u} \quad (19)$$

3) **Operation during Swell:** A voltage swell is considered when any of the PCC phase voltage exceeds 1.1 p.u. In this case, reference load voltage (V_l^*) is set to 1.1 p.u. which results in minimum current injection. Therefore,

$$V_l^* = 1.1 \text{ p.u} \quad (20)$$

b). **Computation of Load Angle (δ)**

Average real power at the PCC (P_{pcc}) is sum of average load power (P_l) and VSI losses (P_{loss}). The real power P_{pcc} is taken from the source depending upon the angle between source and load voltages, i.e., load angle δ . If DSTATCOMdc bus capacitor voltage is regulated to a reference value, then in steady state condition P_{loss} is a constant value and forms a fraction of P_{pcc} . Consequently, δ is also a constant value. The dc link voltage is regulated by generating a suitable value of δ . The average voltage across dc capacitors ($V_{dc1} + V_{dc2}$) is compared with a reference voltage and error is passed through a PI controller. Output of PI controller, δ , is given as

$$\delta = K_{p\delta} e_{vdc} + K_{i\delta} \int e_{vdc} dt \quad (21)$$

Where $e_{vdc} = 2 V_{dcref} - (V_{dc1} + V_{dc2})$ is the voltage error. $K_{p\delta}$ and $K_{i\delta}$ are proportional and integral gains, respectively.

c) **Generation of Instantaneous Reference Voltage**

Selecting suitable reference load voltage magnitude and computing load angle δ from (21), the three phase balanced sinusoidal reference load voltages are given as follows:

$$\begin{aligned} v_{refa} &= \sqrt{2} V_l^* \sin(\omega t - \delta) \\ v_{refb} &= \sqrt{2} V_l^* \sin(\omega t - 2\pi/3 - \delta) \\ v_{refc} &= \sqrt{2} V_l^* \sin(\omega t + 2\pi/3 - \delta) \end{aligned} \quad (22)$$

These voltages are realized by the VSI using a predictive voltage controller.

VII. MATLAB/SIMULINK RESULTS

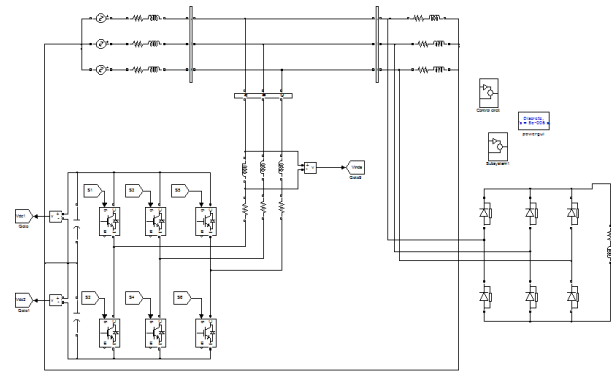

Fig.7 MATLAB/SIMULINK circuit for three phase equivalent circuit of DSTATCOM topology in distribution system

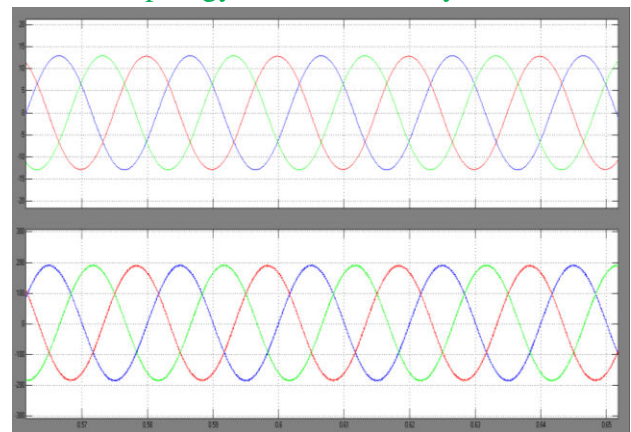

Fig.8 source current and voltage Output waveform

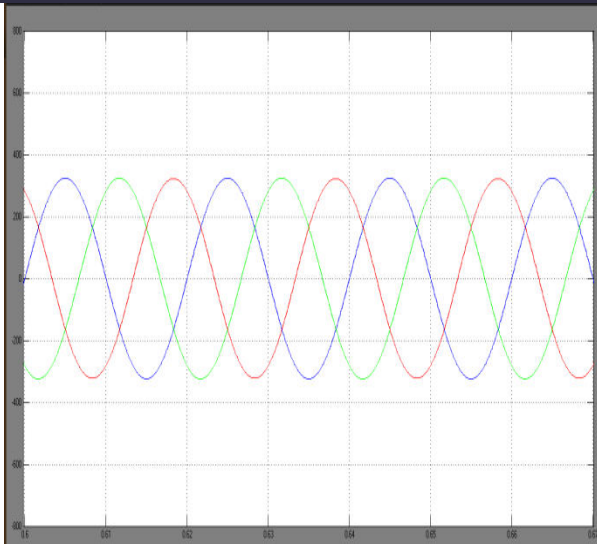

Fig.9 Load voltage output waveform

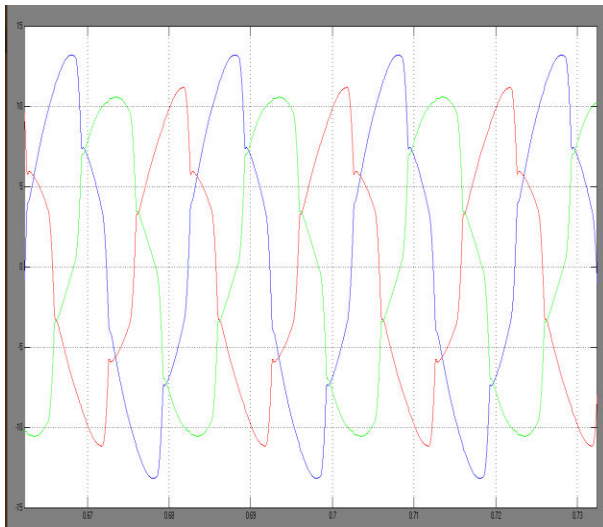

Fig.10 Load current output waveform

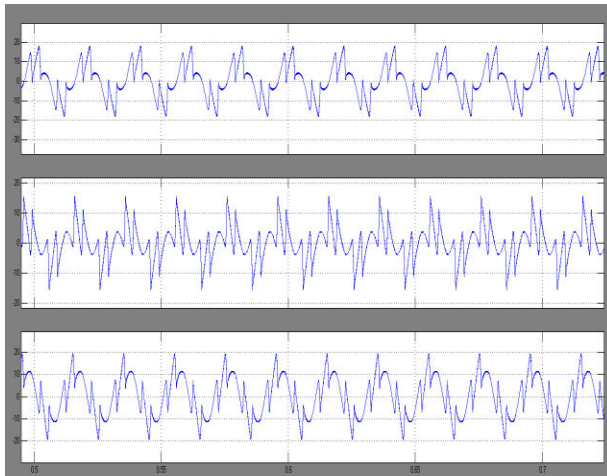
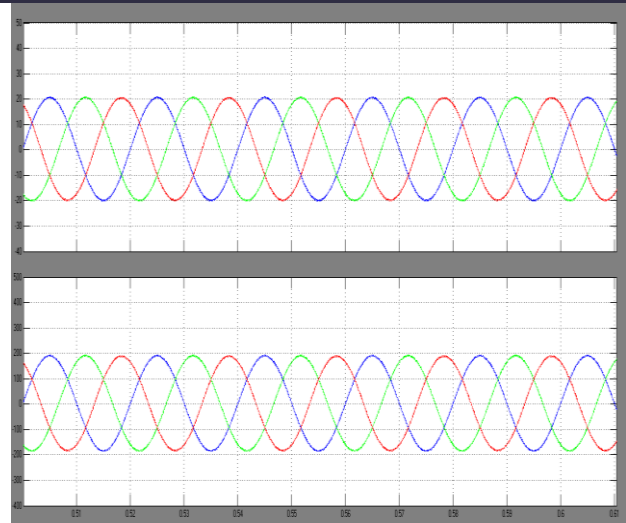
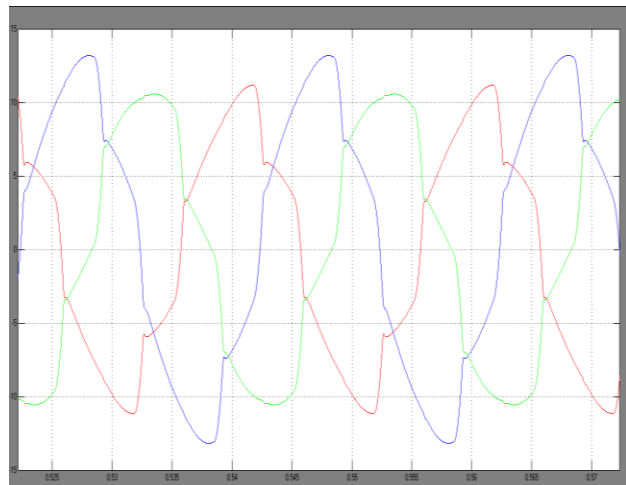

Fig.11 Filter currents output waveform



(a)



(b)

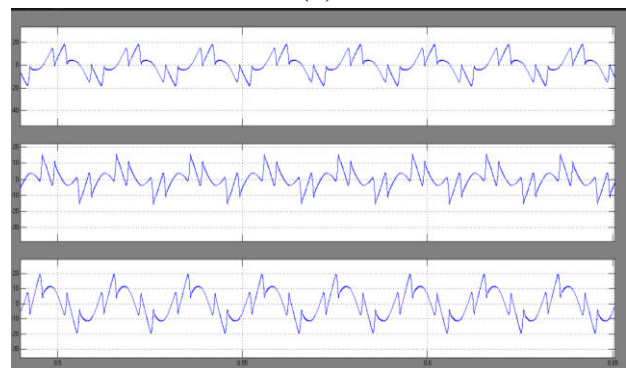

(c)

Fig.12 Output waveform of (a) Source current and voltage, (b) Load current, (c) Filter current during normal operation

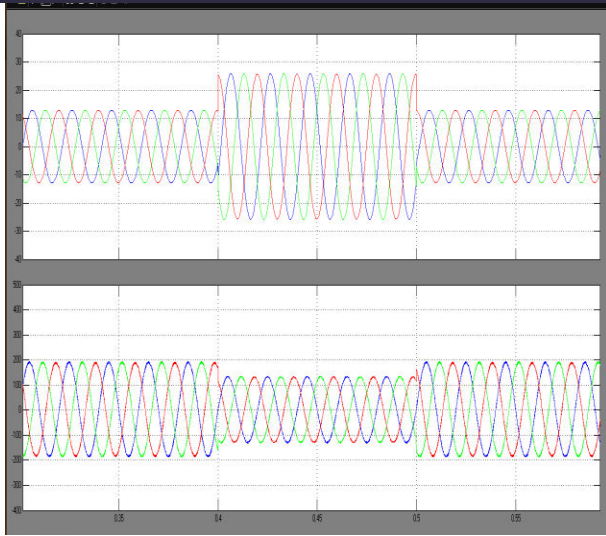

(a)

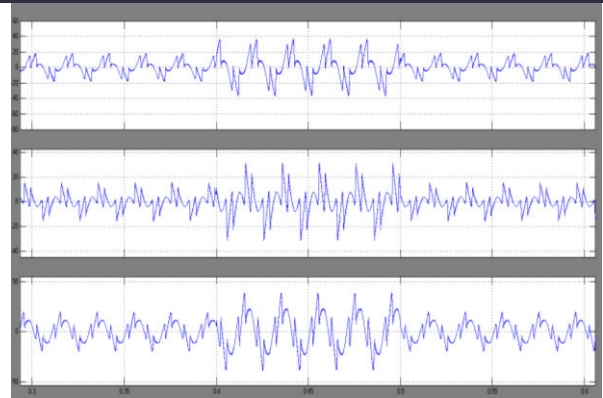

(d)

Fig.13 Output waveform of (a) Source current and voltage, (b) Load voltage (c) Load current, (d) Filter current during normal operation During voltage sag condition

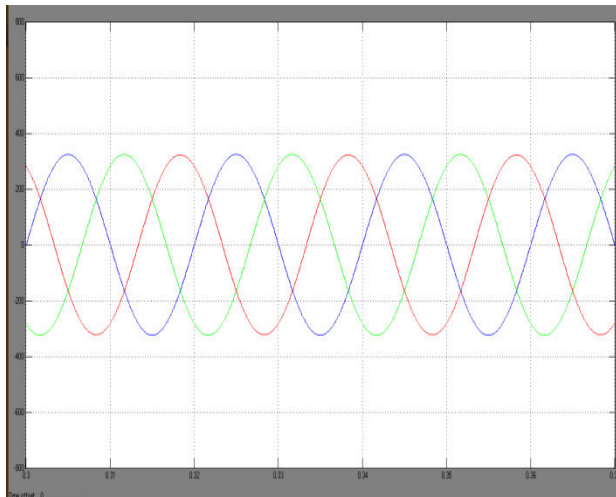

(b)

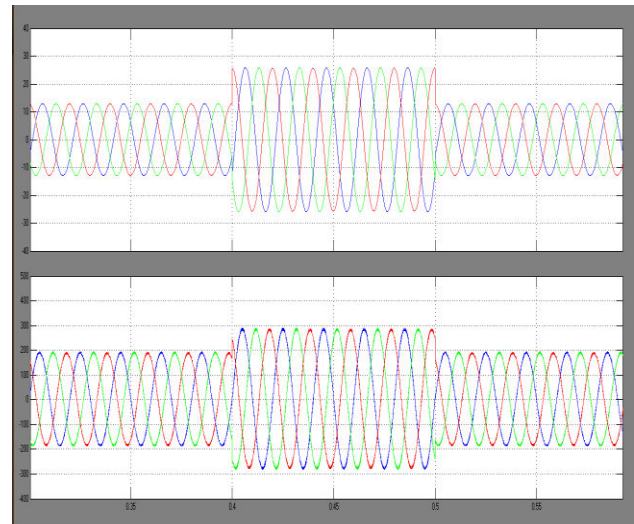

(a)

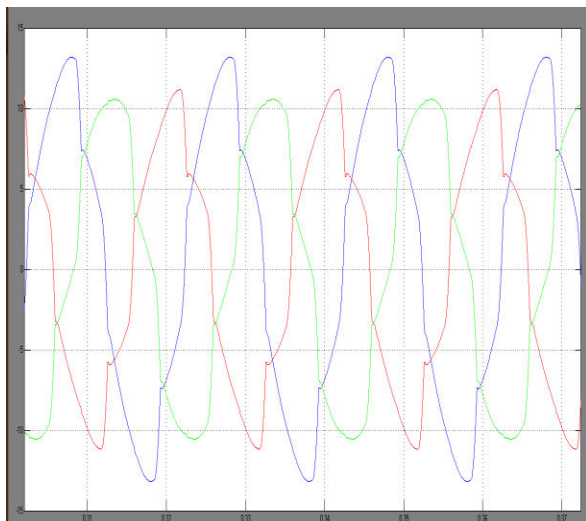

(c)

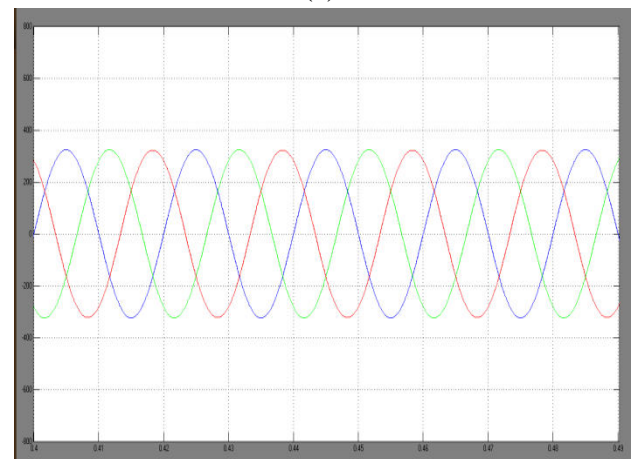

(b)

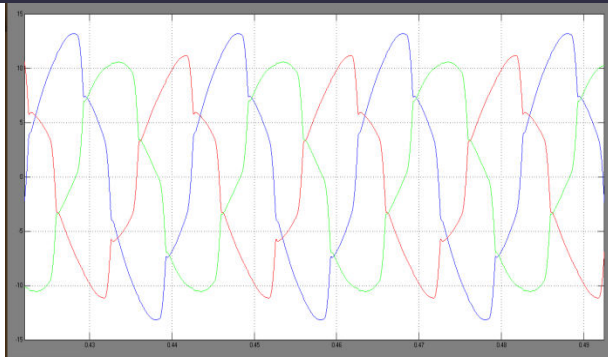

(c)

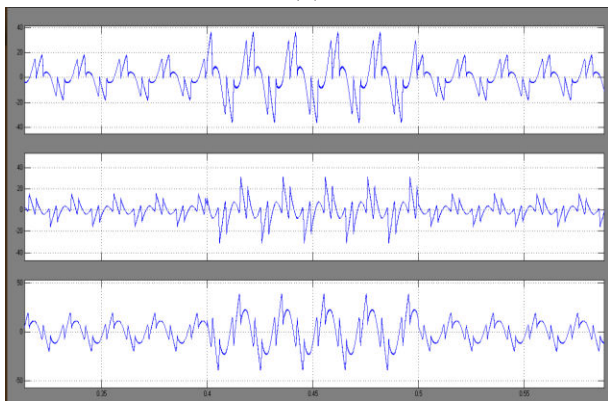

(d)

Fig.14 Output waveform of (a) Source current and voltage, (b) Load voltage (c) Load current, (d) Filter current during normal operation During voltage swell condition

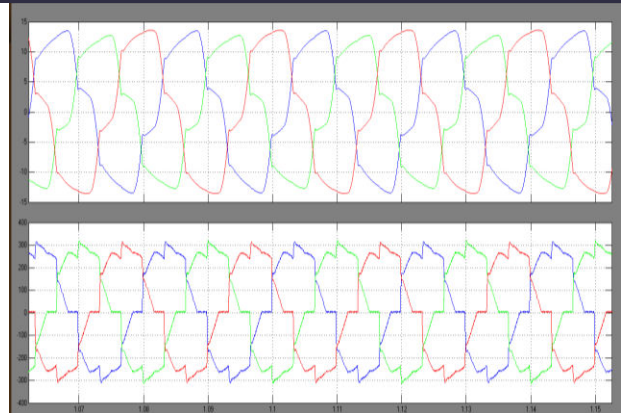

(a)

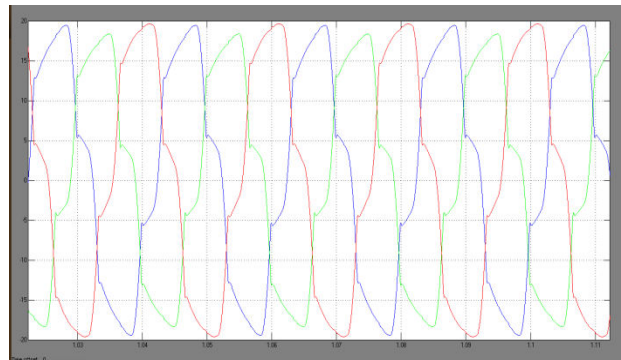

(b)

Fig.16 Output waveform of (a) Source current and voltage, (b) Load current under without DSTATCOM

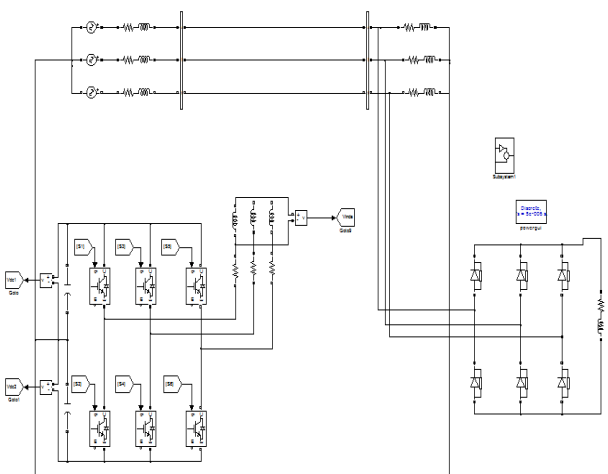

Fig.15 MATLAB/SIMULINK circuit for three phase equivalent circuit without DSTATCOM topology in distribution system

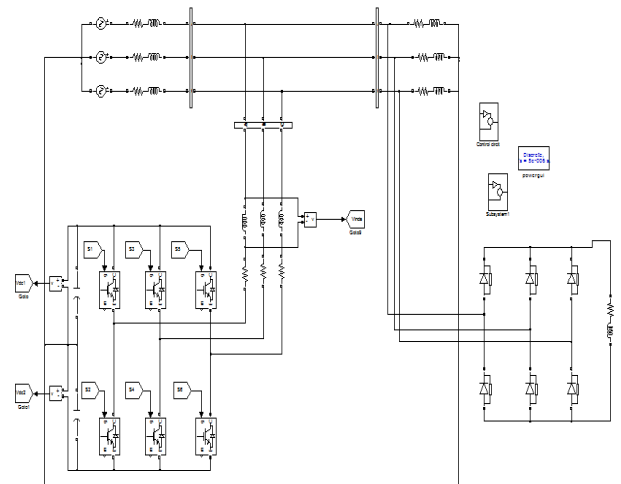
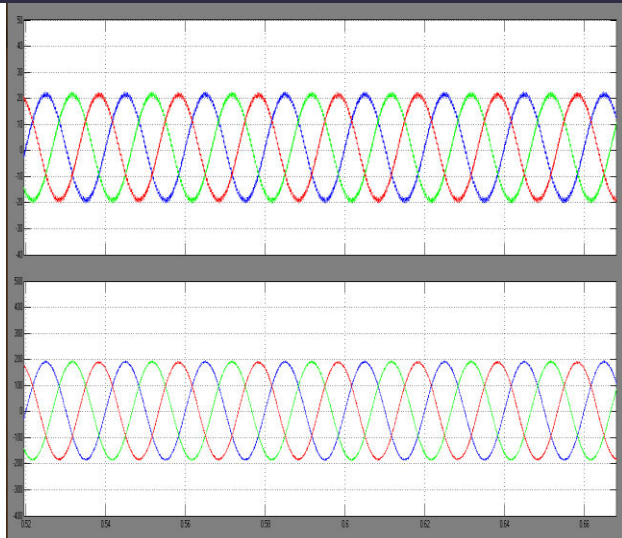
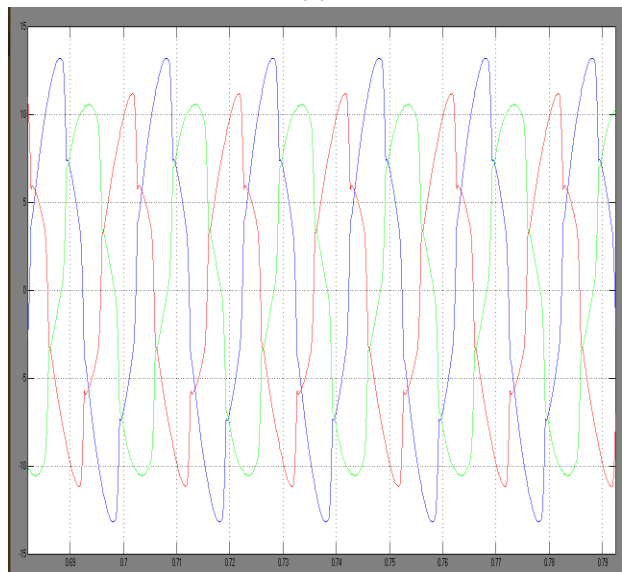

Fig.17 MATLAB/SIMULINK circuit for three phase equivalent circuit of DSTATCOM topology in distribution system with PI controller



(a)



(b)

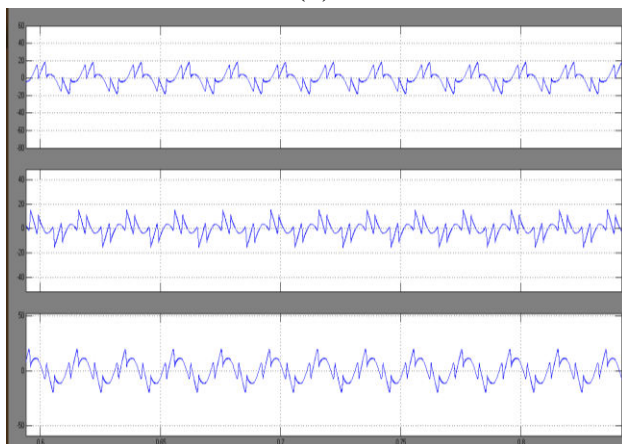

(c)

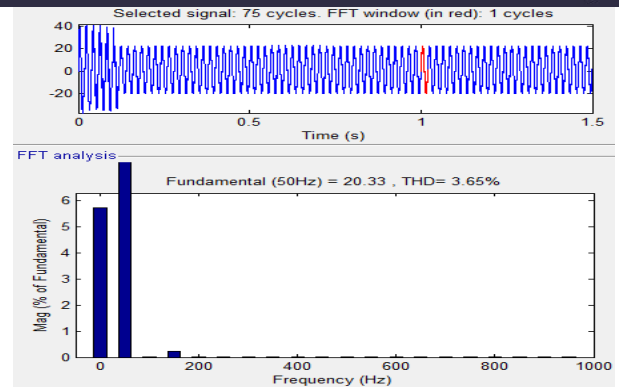

(d)

Fig.18 Output waveform of (a) Source current and voltage, (b) Load current, (c) Filter current (d) THD plot of source current by using PI controller

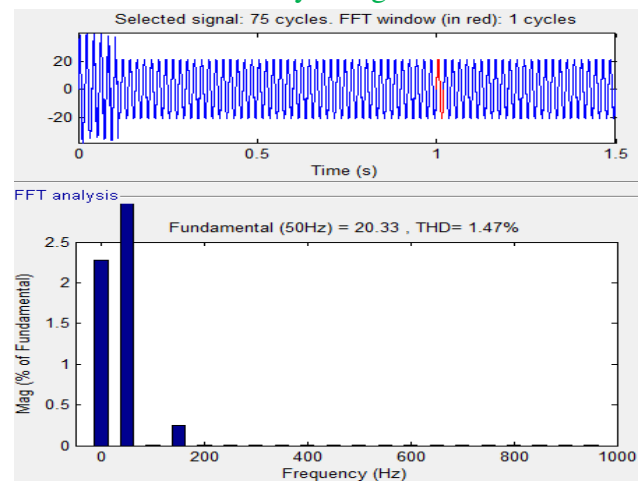

Fig.19 THD plot of source current by using Fuzzy logic controller

VII. CONCLUSION

In this paper we study the problem of transient disturbances in power systems. We implement fuzzy logic controller with D-STATCOM. The performance of proposed method is compared with PI based D-STATCOM. Simulation results revealed that the proposed model free intelligent control (fuzzy) methodology based D-STATCOM tackle power quality issues such as Harmonic Reduction considerable by introducing fuzzy controller based D-STATCOM. The simulation results shows that

the voltage sags can be mitigate by inserting DSTATCOM to the distribution system. By adding LCL Passive filter to D-STATCOM and Fuzzy Logic, the THD is within the standard Limits. The power factors also increase close to unity. Thus, it can be concluded that by adding DSTATCOM with LCL filter can eliminate voltage sag and can improve Power quality in the distribution system.

REFERENCES

- [1] R. C. Dugan, M. F. McGranaghan, and H. W. Beaty, *Electric Power Systems Quality*, 2nd ed. New York, NY, USA: McGraw-Hill, 2006.
- [2] A. Ortiz, C. Gherasim, M. Manana, C. J. Renedo, L. I. Eguiluz, and R. J. M. Belmans, "Total harmonic distortion decomposition depending on distortion origin," *IEEE Trans. Power Del.*, vol. 20, no. 4, pp. 2651– 2656, Oct. 2005.
- [3] T. L. Lee and S. H. Hu, "Discrete frequency-tuning active filter to suppress harmonic resonances of closed-loop distribution power systems," *IEEE Trans. Power Electron.*, vol. 26, no. 1, pp. 137–148, Jan. 2011.
- [4] K. R. Padiyar, *FACTS Controllers in Power Transmission and Distribution*. New Delhi, India: New Age Int., 2008.
- [5].IEEE Recommended Practices and requirement for Harmonic Control on electric power System, IEEE Std.519, 1992.
- [6].Tzung-Lin Lee, Shang-Hung Hu and Yu-Hung Chan, "DSTATCOM with positive-sequence admittance and negative-sequence conductance to mitigate voltage fluctuations in high-level penetration of distributed generation systems," *IEEE Transactions on Industrial Electronics*, vol. 60, no. 4, pp. 1417-1428, April 2013
- [7].B. Singh, P. Jayaprakash and D.P. Kothari, "Power factor correction and power quality improvement in the distribution system," *Journal of Electrical India*, pp. 40- 48, April, 2008.
- [8] J.-C. Wu, H. L. Jou, Y. T. Feng, W. P. Hsu, M. S. Huang, and W. J. Hou, "Novel circuit topology for three-phase active power filter," *IEEE Trans. Power Del.*, vol. 22, no. 1, pp. 444– 449, Jan. 2007.
- [9] Z. Yao and L. Xiao, "Control of single-phase grid connected inverters with nonlinear loads," *IEEE Trans. Ind. Electron.*, vol. 60, no. 4, pp. 1384– 1389, Apr. 2013.
- [10] A. A. Heris, E. Babaei, and S. H. Hosseini, "A new shunt active power filter based on indirect matrix converter," in *Proc. 20th Iranian Conf. Elect. Eng.*, 2012, pp. 581–586.
- [11] M. Sadeghi, A. Nazarloo, S. H. Hosseini, and E. Babaei, "A new DSTATCOM topology based on stacked multicell converter," in *Proc. 2nd Power Electron., Drive Syst. Technol. Conf.*, 2011, pp. 205–210.
- [12] G. Benysek and M. Pasko, *Power Theories for Improved Power Quality*. London, U.K.: Springer-Verlag, 2012.
- [13] B. Singh and J. Solanki, "A comparison of control algorithms for DSTATCOM," *IEEE Trans. Ind. Electron.*, vol. 56, no. 7, pp. 2738– 2745, Jul. 2009.
- [14] C. H. da Silva, R. R. Pereira, L. E. B. da Silva, G. Lambert-Torres, B. K. Bose, and S. U. Ahn, "A digital PLL scheme for three-phase system using modified synchronous reference frame," *IEEE Trans. Ind. Electron.*, vol. 57, no. 11, pp. 3814–3821, Nov. 2010.