

GRIDCONNECTED VOLTAGE SOURCE INVERTER WITH ENHANCED POWER QUALITY

A NARESH

Assistant Professor, Department of Electrical and Electronics Engineering, Siddhartha Institute of Technology and Sciences, Narapally, Hyderabad, Telangana, India

Abstract: This paper uncovers a double voltage source inverter (DVSI) plan to improve the vitality quality and reliability of the smaller scale lattice framework. The proposed conspire is comprised of two inverters, which allows the small scale lattice to switch control made by the conveyed vitality assets (DERs) and to repay the area uneven and nonlinear weight. The control calculations are produced predicated on prompt symmetrical viewpoint hypothesis (ISCT) to utilize DVSI in matrix posting and framework infusing settings. The proposed design has expanded reliability, bring down transmission capacity reliance on the key inverter, more affordable because of diminishing in filtration size, and better utilization of smaller scale lattice capacity when utilizing lessened dcinterface voltage score for the key inverter. The DVSI is fabricated by these highlights plan a promising choice for small scale framework giving overly sensitive parcels. The control and topology calculation are approved through thorough reproduction and test comes about.

Keywords: DVSI, Instantaneous Symmetrical Aspect Theory (ISCT), DERs

I. INTRODUCTION

Technological progress and environmental concerns drive the power system to a paradigm shift with more renewable energy sources integrated to the network by means of distributed generation (DG). These DG units with coordinated control of local generation and storage facilities form a micro grid. In a micro grid, power from different renewable energy sources such as fuel cells, photovoltaic (PV) systems, and wind energy systems are interfaced to grid and loads using power electronic converters. A grid interactive inverter plays an important role in exchanging power from the micro grid to the grid and the connected

load. This micro grid inverter can either work in a grid sharing mode while supplying a part of local load or in grid injecting mode, by injecting power to the main grid. Maintaining power quality is another important aspect which has to be addressed while the micro grid system is connected to the main grid. The proliferation of power electronics devices and electrical loads with unbalanced nonlinear currents has degraded the power quality in the power distribution network. Moreover, if there is a considerable amount of feeder impedance in the distribution systems, the propagation of these harmonic currents distorts the voltage at the point of

common coupling (PCC). At the same instant, industry automation has reached to a very high level of sophistication, where plants like automobile manufacturing units, chemical factories, and semiconductor industries require clean power. For these applications, it is essential to compensate nonlinear and unbalanced load currents. In, a voltage regulation and power flow control scheme for a wind energy system (WES) is proposed. A distribution static compensator (DSTATCOM) is utilized for voltage regulation and also for active power injection. The control scheme maintains the power balance at the grid terminal during the wind variations using sliding mode control. A multifunctional power electronic converter for the DG power system is described in. This scheme has the capability to inject power generated by WES and also to perform as a harmonic compensator. Most of the reported literature in this area discuss the topologies and control algorithms to provide load compensation capability in the same inverter in addition to their active power injection. When a grid-connected inverter is used for active power injection as well as for load compensation, the inverter capacity that can be utilized for achieving the second objective is decided by the available instantaneous micro grid real power. Considering the case of a grid-connected PV inverter, the available capacity of the inverter to supply the reactive power becomes less during the maximum solar insolation periods. At the same instant, the reactive power to regulate the PCC voltage is very much needed during this period. It

indicates that providing multi functionalities in a single inverter degrades either the real power injection or the load compensation capabilities.

II. ELECTRIC POWER QUALITY

Electric power quality (EPQ), or simply Power quality, refers to "maintaining the near sinusoidal waveform of power distribution bus voltages and currents at rated magnitude and frequency.",[1] determining the fitness of electric power to consumer devices. Synchronization of the voltage frequency and phase allows electrical systems to function in their intended manner without significant loss of performance or life. The term is used to describe electric power that drives an electrical load and the load's ability to function properly. Without the proper power, an electrical device (or load) may malfunction, fail prematurely or not operate at all. There are many ways in which electric power can be of poor quality and many more causes of such poor quality power. The electric power industry comprises electricity generation (AC power), electric power transmission and ultimately electric power distribution to an electricity meter located at the premises of the end user of the electric power. The electricity then moves through the wiring system of the end user until it reaches the load. The complexity of the system to move electric energy from the point of production to the point of consumption combined with variations in weather, generation, demand and other factors provide many opportunities for the quality of supply to be compromised. While "power quality" is a convenient term for

many, it is the quality of the voltage rather than power or electric current that is actually described by the term. Power is simply the flow of energy and the current demanded by a load is largely uncontrollable.

III. DUAL VOLTAGE SOURCE INVERTER

A. System Topology

The proposed DVSI topology is shown in Fig. 1. It consists of a neutral point clamped (NPC) inverter to realize AVSI and a three-leg inverter for MVSI. These are connected to grid at the PCC and supplying a nonlinear and unbalanced load. The function of the AVSI is to compensate the reactive, harmonics, and unbalance components in load currents. Here, load currents in three phases are represented by i_{la} , i_{lb} , and i_{lc} , respectively. Also, $i_{g(abc)}$, $i_{\mu gm(abc)}$, and $i_{\mu gx(abc)}$ show grid currents, MVSI currents, and AVSI currents in three phases, respectively. The dc link of the AVSI utilizes a split capacitor topology, with two capacitors $C1$ and $C2$. The MVSI delivers the available power at distributed energy resource (DER) to grid. The DER can be a dc source or an ac source with rectifier coupled to dc link. Usually, renewable energy sources like fuel cell and PV generate power at variable low dc voltage, while the variable speed wind turbines generate power at variable ac voltage. Therefore, the power generated from these sources use a power conditioning stage before it is connected to the input of MVSI

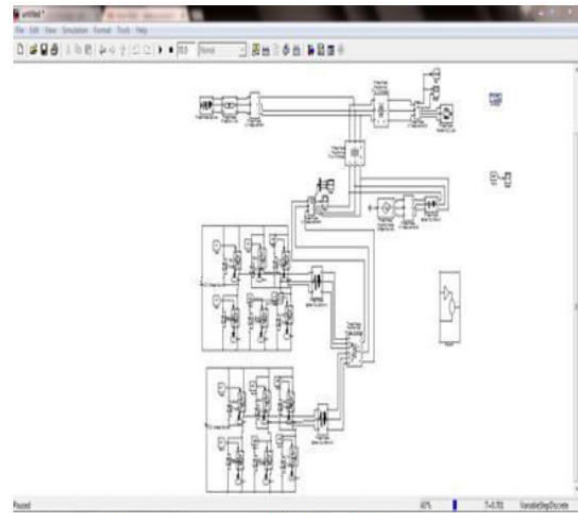

Fig1. Topology of proposed DVSI scheme.

In this study, DER is being represented as a dc source. An inductor filter is used to eliminate the high-frequency switching components generated due to the switching of power electronic switches in the inverters. The system considered in this study is assumed to have some amount of feeder resistance R_g and inductance L_g . Due to the presence of this feeder impedance, PCC voltage is affected with harmonics. Section III describes the extraction of fundamental positive sequence of PCC voltages and control strategy for the reference current generation of two inverters in DVSI scheme.

B. Design of DVSI Parameters

AVSI: The important parameters of AVSI like dc-link voltage (V_{dc}), dc storage capacitors ($C1$ and $C2$), interfacing inductance (L_{fx}), and hysteresis band ($\pm h_x$) are selected based on the design method of split capacitor DSTATCOM topology. The dc-link voltage across each capacitor is taken as 1.6 times the peak of phase voltage. The total dc-link voltage reference (V_{dref}) is found to be 1040 V. Values of dc capacitors of AVSI are chosen based on the change in dc-link voltage during transients.

Let total load rating is S kVA. In the worst case, the load power may vary from minimum to maximum, i.e., from 0 to S kVA. AVSI needs to exchange real power during transient to maintain the load power demand. This transfer of real power during the transient will result in deviation of capacitor voltage from its reference value. Assume that the voltage controller takes n cycles, i.e., nT seconds to act, where T is the system time period. Hence, maximum energy exchange by AVSI during transient will be nST. This energy will be equal to change in the capacitor stored energy. Therefore

$$\frac{1}{2}C_1(V_{dcr}^2 - V_{dc1}^2) = nST \quad (1)$$

where Vdcr and Vdc1 are the reference dc voltage and maximum permissible dc voltage across C1 during transient, respectively. Here, S =5 kVA, Vdcr = 520 V, Vdc1 = 0.8 Vdcr or 1.2 Vdcr, n = 1, and T = 0.02 s. Substituting these values in (1), the dclink capacitance (C1) is calculated to be 2000 μF. Same value of capacitance is selected for C2. The interfacing inductance is given by

$$L_{fx} = \frac{1.6 V_m}{4 h_x f_{max}} \quad (2)$$

Assuming a maximum switching frequency (fmax) of 10 kHz and hysteresis band (hx) as 5% of load current (0.5 A), the value of Lfx is calculated to be 26 mH. 2) MVSI: The MVSI uses a three-leg inverter topology. Its dc-link voltage is obtained as 1.15 Vml, where Vml is the peak value of line voltage. This is calculated to be 648 V. Also, MVSI supplies a balanced sinusoidal current at unity power factor. So, zero

sequence switching harmonics will be absent in the output current of MVSI. This reduces the filter requirement for MVSI as compared to AVSI. In this analysis, a filter inductance (Lfm) of 5 mH is used.

C. Advantages of the DVSI Scheme

The various advantages of the proposed DVSI scheme over a single inverter scheme with multifunctional capabilities are discussed here as follows:

1. Increased Reliability: DVSI scheme has increased reliability, due to the reduction in failure rate of components and the decrease in system down time cost. In this scheme, the total load current is shared between AVSI and MVSI and hence reduces the failure rate of inverter switches. Moreover, if one inverter fails, the other can continue its operation. This reduces the lost energy and hence the down time cost. The reduction in system down time cost improves the reliability.

2. Reduction in Filter Size: In DVSI scheme, the current supplied by each inverter is reduced and hence the current rating of individual filter inductor reduces. This reduction in current rating reduces the filter size. Also, in this scheme, hysteresis current control is used to track the inverter reference currents. As given in (2), the filter inductance is decided by the inverter switching frequency. Since the lower current rated semiconductor device can be switched at higher switching frequency, the inductance of the filter can be lowered. This decrease in inductance further reduces the filter size.

3. Improved Flexibility: Both the inverters are fed from separate dc links which allow them to operate independently, thus increasing the flexibility of the system. For instance, if the dc link of the main inverter is disconnected from the system, the load compensation capability of the auxiliary inverter can still be utilized.

4. Better Utilization of Microgrid Power: DVSI scheme helps to utilize full capacity of MVSI to transfer the entire power generated by DG units as real power to ac bus, as there is AVSI for harmonic and reactive power compensation. This increases the active power injection capability of DGs in micro grid.

5. Reduced DC-Link Voltage Rating: Since, MVSI is not delivering zero sequence load current components, a single capacitor three-leg VSI topology can be used. Therefore, the dclink voltage rating of MVSI is reduced approximately by 38%, as compared to a single inverter system with split capacitor VSI topology

D. GRID-TIE Inverter

A grid-tie inverter is a power inverter that converts direct current (DC) electricity into alternating current (AC) with an ability to synchronize to interface with a utility line. Its applications are converting DC sources such as solar panels or small wind turbines into AC for tying with the grid. Residences and businesses that have a grid-tied electrical system are permitted in many countries to sell their energy to the utility grid. Electricity delivered to the grid can be compensated in several ways. "Net metering" is where the entity that owns the renewable energy power source receives

compensation from the utility for its net outflow of power. So for example, if during a given month a power system feeds 500 kilowatt-hours into the grid and uses 100 kilowatt-hours from the grid, it would receive compensation for 400 kilowatthours. In the US, net metering policies vary by jurisdiction. Another policy is a feed-in tariff, where the producer is paid for every kilowatt hour delivered to the grid by a special tariff based on a contract with distribution company or other power authority. In the United States, grid-interactive power systems are covered by specific provisions in the National Electric Code, which also mandates certain requirements for gridinteractive inverters.

E. Typical Operation

Inverters take DC power and invert it to AC power so it can be fed into the electric utility company grid. The grid tie inverter (GTI) must synchronize its frequency with that of the grid (e.g. 50 or 60 Hz) using a local oscillator and limit the voltage to no higher than the grid voltage. A high-quality modern GTI has a fixed unity power factor, which means its output voltage and current are perfectly lined up, and its phase angle is within 1 degree of the AC power grid. The inverter has an on-board computer which senses the current AC grid waveform, and outputs a voltage to correspond with the grid. However, supplying reactive power to the grid might be necessary to keep the voltage in the local grid inside allowed limitations. Otherwise, in a grid segment with considerable power from renewable sources, voltage levels might rise too much at times of high production, i.e. around

noon. Grid-tie inverters are also designed to quickly disconnect from the grid if the utility grid goes down. This is an NEC requirement that ensures that in the event of a blackout, the grid tie inverter will shut down to prevent the energy it transfers from harming any line workers who are sent to fix the power grid. Properly configured, a grid tie inverter enables a home owner to use an alternative power generation system like solar or wind power without extensive rewiring and without batteries. If the alternative power being produced is insufficient, the deficit will be sourced from the electricity grid.

F. Technology

Technologies available to grid-tie inverters include newer high-frequency transformers, conventional low-frequency transformers, or they may operate without transformers altogether. Instead of converting direct current directly to 120 or 240 volts AC, high-frequency transformers employ a computerized multi-step process that involves converting the power to high-frequency AC and then back to DC and then to the final AC output voltage. Transformer less inverters, lighter are more efficient than their counterparts with transformers, are popular in Europe. However, transformer less inverters have been slow to enter the US market over concerns that transformer less electrical systems could feed into the public utility grid without galvanic isolation between the DC and AC circuits that could allow the passage of dangerous DC faults to be transmitted to the AC side.[4] However, since 2005, the NFPA's NEC allows transformer less (or non-galvanically)

inverters by removing the requirement that all solar electric systems be negative grounded and specifying new safety requirements. The VDE 0126-1-1 and IEC 6210 also have been amended to allow and define the safety mechanisms needed for such systems. Primarily, residual or ground current detection is used to detect possible fault conditions. Also isolation tests are performed to ensure DC to AC separation.



Fig2. Inside of a SWEA 250W Transformer-based grid-tie inverter.

IV. EXPERMETAL RESULT

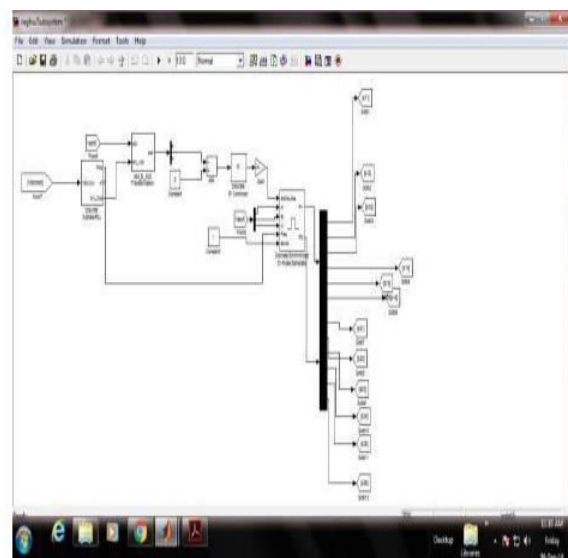

Fig3. Simulation diagram showing the control strategy of proposed D VSI scheme.

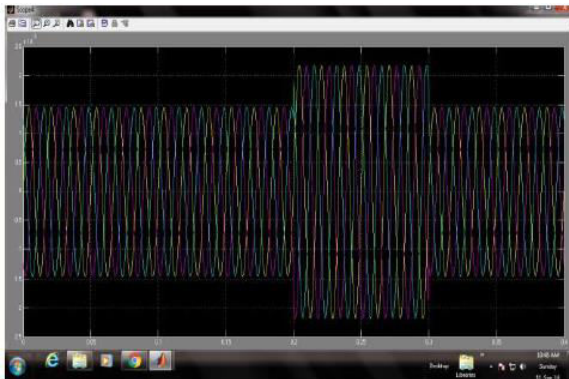

Fig4. Voltage swell during non linear load parallel to the dual inverter connected load.

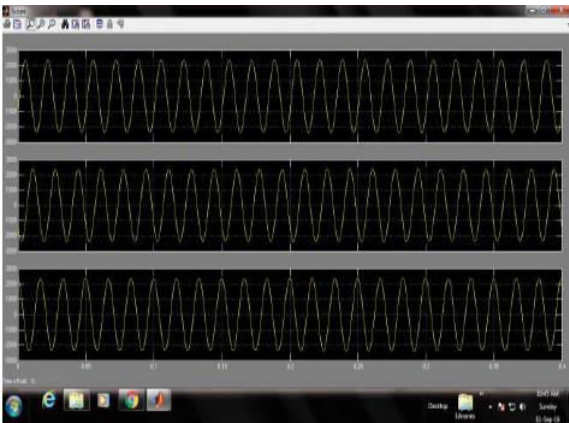

Fig5. 3-phase voltages of dual inverter fed line.

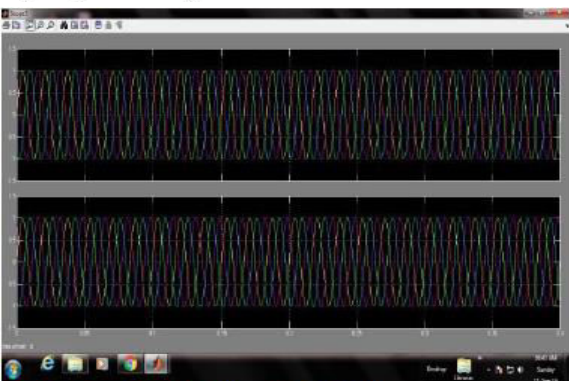

Fig6. 3-phase load voltages and currents.

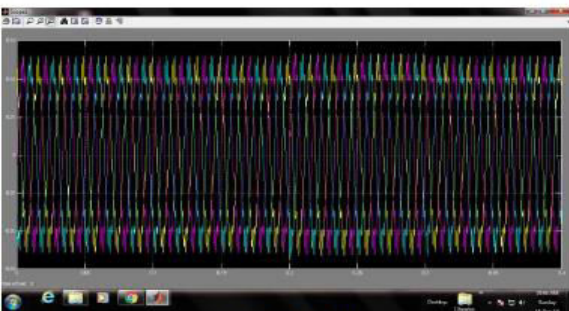

Fig7. 3-phase currents of dual fed line.

V. CONCLUSION

A DVSI scheme is proposed for micro grid systems with enhanced power quality. Control algorithms are developed to generate reference currents for DVSI using ISCT. The proposed scheme has the capability to exchange power from distributed generators (DGs) and also to compensate the local unbalanced and nonlinear load. The performance of the proposed scheme has been validated through simulation and experimental studies. As compared to a single inverter with multifunctional capabilities, a DVSI has many advantages such as, increased reliability, lower cost due to the reduction in filter size, and more utilization of inverter capacity to inject real power from DGs to micro grid. Moreover, the use of three-phase, three wire topology for the main inverter reduces the dc-link voltage requirement. Thus, a DVSI scheme is a suitable interfacing option for micro grid supplying sensitive loads.

VI. REFERENCES

- [1] A. Kahrobaeian and Y.-R. Mohamed, —Interactive distributed generation interface for flexible micro-grid operation in smart distribution systems,|| IEEE Trans. Sustain. Energy, vol. 3, no. 2, pp. 295–305, Apr. 2012.
- [2] N. R. Tummuru, M. K. Mishra, and S. Srinivas, —Multifunctional VSC controlled microgrid using instantaneous symmetrical components theory,|| IEEE Trans. Sustain. Energy, vol. 5, no. 1, pp. 313–322, Jan. 2014.
- [3] Y. Zhang, N. Gatsis, and G. Giannakis, —Robust energy management for

microgrids with high-penetration renewables,|| *IEEE Trans. Sustain. Energy*, vol. 4, no. 4, pp. 944–953, Oct. 2013.

[4] R. Majumder, A. Ghosh, G. Ledwich, and F. Zare, —Load sharing and power quality enhanced operation of a distributed microgrid,|| *IET Renewable Power Gener.*, vol. 3, no. 2, pp. 109–119, Jun. 2009.

[5] J. Guerrero, P. C. Loh, T.-L. Lee, and M. Chandorkar,—Advanced control architectures for intelligent microgrids—Part II: Power quality, energy storage, and ac/dc microgrids,|| *IEEE Trans. Ind. Electron.*, vol. 60, no. 4, pp. 1263–1270, Dec. 2013.

[6] Y. Li, D. Vilathgamuwa, and P. C. Loh, —Microgrid power quality enhancement using a three-phase four-wire gridinterfacing compensator,|| *IEEE Trans. Ind. Appl.*, vol. 41, no.

6, pp. 1707–1719, Nov. 2005.

[7] M. Schonardie, R. Coelho, R. Schweitzer, and D. Martins, —Control of the active and reactive power using dq0 transformation in a three-phase grid-connected PV system,|| in *Proc. IEEE Int. Symp. Ind. Electron.*, May 2012, pp. 264–269.

[8] R. S. Bajpai and R. Gupta, —Voltage and power flow control of grid connected wind generation system using DSTATCOM,|| in *Proc. IEEE Power Energy Soc. Gen. Meeting—Convers. Del. Elect. Energy 21st Century*, Jul. 2008, pp. 1–6.

[9] M. Singh, V. Khadkikar, A. Chandra, and R. Varma, —Grid interconnection of renewable energy sources at the distribution level with power-quality improvement

features,|| *IEEE Trans. Power Del.*, vol. 26, no. 1, pp. 307–315, Jan. 2011.

[10] H.-G. Yeh, D. Gayme, and S. Low, —Adaptive VAR control for distribution circuits with photovoltaic generators,|| *IEEE Trans. Power Syst.*, vol. 27, no. 3, pp. 1656–1663, Aug. 2012.

[11] C. Demoulias, —A new simple analytical method for calculating the optimum inverter size in grid-connected PV plants,|| *Electr. Power Syst. Res.*, vol. 80, no. 10, pp. 1197–1204, 2010.

[12] R. Tonkoski, D. Turcotte, and T. H. M. EL-Fouly, —Impact of high PV penetration on voltage profiles in residential neighborhoods,|| *IEEE Trans. Sustain. Energy*, vol. 3, no. 3, pp. 518–527, Jul. 2012.