

ARM 7 Based Prepaid Energy Meter to Control Electricity Theft in Smart Grid

A DEEPIKA

Assistant Professor, Department of Electronics and Communication Engineering, Siddhartha Institute of Technology and Sciences, Narapally, Hyderabad, Telangana, India

ABSTRACT: In this project Design and development of smart monitoring and controlling system for household electrical appliances in real time is proposed. we propose an intelligent energy distribution system with a fixed power use of every home set from Electricity Board(EB) office. Power distribution from EB is the major issue because of shortage in power generation from renewable and non-renewable resources. We design this, in order to reduce the frequent power cut off. Moreover monitoring and controlling of home appliances is developed either manually, remotely and with the help of Bluetooth. The main aim is to provide low cost and flexible operation. Current bill automatically send to householder through IOT and giving alert message also. power theft is a problem that continues to plague power sector across whole country the objective of this project is to design such a system which will try to reduce the illegal use of electricity and also reduce the chances of theft. This project will automatically collect the reading and also detect the theft

1.1 INTRODUCTION:

Generation, transmission and distribution of electrical energy involve many operational losses. Whereas, losses implicated in generation can be technically defined, but transmission and distribution losses cannot be precisely quantified with the sending end information. This illustrates the involvement of nontechnical parameter in transmission and distribution of electricity. Overall technical losses occur naturally and are caused because of power dissipation in transmission lines, transformers, and other power system components. Technical

losses in T&D are computed with the information about total load and the total energy bill. While technology in on the raising slopes, we should also note the increasing immoral activities. With a technical view, Power Theft is a non ignorable crime and at the same time it directly affected the economy of a nation. Electricity theft a social evil, so it has to be completely eliminated. Power consumption and losses have to be closely monitored so that the generated power is utilized in a most efficient manner. The system prevents the illegal usage of electricity. At this point of technological development the problem of illegal usage of

electricity can be solved electronically without any human control. The implementation of this system will save large amount of electricity, and there by electricity will be available for more number of consumer then earlier, in highly populated country such as INDIA.

2. LITERATURE SURVEY

Following is the brief description of work done on theft detection models by various researchers:-

The paper uses the approach based on power line communication principle which is use for detecting theft in electricity. A high frequency signal is introduced in the distribution network which changes its amplitude and frequency as the load in the lines increases or decreases. The changes will be detected through the gain detectors if any illegal connection is made between the poles then there will be modification in the values of gain and through which the illegal connection in the electricity will be discovered and proper action will be taken by the authorities to neutralize such connection but this approach is not tried for the theft detection for the customers illegal use and it is infrastructure based.

Uses the concept of customer's historic usage pattern of electricity to create the user load profiling information which is used to detect the unusual flow of electricity and thus provides the

class of customers which could be further synthesized to detect possible fraud customers. The paper uses many concepts like Extreme Learning Machine, Support Vector Machine. There are Firstly the usage data of customers is pre-processed. The processing is done in three steps Data Selection, Data Separation and Data Normalization. Then there is the process of feature selection which automatically takes the important features of the data. Then the data is categorized by the abnormal usage patterns by using ELM. Then the categorized data is further classified by SVM to detect the possible fraud in electricity. But as we are using SVM. The accuracy of detection decreases as SVM is not accurate in classifying data to the extent so there is possibility of getting failure in detection of fraud.

States the idea of computational techniques to classify the electricity consumption profiles of users. The paper uses two-step process to reach to the results. Firstly the cmeans based on fuzzy clustering, is performed to find customers with similar usage profiles and then fuzzyclassification is executed on the fuzzy cluster values and fraud matrix values using distance based approach. Then the gradation is done on the bases of the deflection. The greater the value of the grade the greater is the probability of fraud. the fuzzy c-means clustering technique used for clustering gives the higher chances of likeliness detection between

the normal and abnormal behavior of the customers usage. The profiles for the user are made from usage of five attributes mainly average consumption of specific client in 6 months, maximum consumption in 6 months, standard deviation, sum of inspection remarks in last six months, average power consumption of that area also the clustering is done using these three parameters. The classification is performed on the basis of 12 months data after the data used for classification. Thus after this we get the degree of abnormality in the usage and by use of proper threshold the faulty customers could be found out. But this method has a drawback in terms of accuracy issues though fuzzy-clustering and classification gives good accuracy but there are still the chances that the training set fuzzy clusters may not yield an accurate load profile as only 6 months data cycle is used

The paper uses the Atkinson index approach for measuring the ill outcomes. As Atkinson index is mainly associated with the distribution of quantities over a spread in terms of income. This approach with the help of the concepts like relative Lorenz curve is used to apply the Atkinson index efficiently to measure the values like pollution. But however due to this transformation the Atkinson index will be used solely for deriving the bad outcomes only there would be no comparison between good and bad outcomes by use of this approach. This this would be beneficial for us to detect the unequal

distribution in terms of electricity efficiently by use of this approach.

A comparison has been done on the basis K-Means and hierarchical clustering on intrusion datasets. Hierarchical clustering: When event occurs, it is the based on the nodes which detect it will be formed and the election algorithm elects a Coordinator for each cluster which is Cluster Head (CH) and deliver Cluster Configuration Message (CCM), identified as $\langle \text{Type, ID, HTT, State, W I} \rangle$, where ID is the identifier and W is the energy factor for each node u. The CH has the extreme energy among all the nodes in the cluster.

K-means:

To find the cluster consider the consume data according to that from a cluster by using distance measure from a group. Similar data of consumer from a one cluster and dissimilar data of consumer from another cluster. K-means clustering is the simplest unsupervised clustering technique. This algorithm takes parameter k as input and partition it into n dataset into k cluster so to obtain the intra-cluster equality is high and inter-cluster equality is low. K is a positive integer number given in advance. It takes minimum time as compared to the hierarchical clustering and yields very better results.

3 PROBLEM STATEMENT

In this existing system wireless communication system of energy meter used with Zigbee, relay control and GPRS. The cryptographic method is used to secure the communication channel and zigbee for the transmission of data in a serial process. Drawback of this process is to collect the readings, going in the particular range of area and manually cut power supply if needed.

4 PROPOSED Work

In this proposed system GSM technology used to transmit the meter reading to the customer and government with the required cost. This process will be happen when needed that means if SMS is received from authorized server mobile transmission between customer and government. Then the energy theft controlled by IR sensor, Bypass detection. Also cut the power supply automatically as per request of authorized server mobile.

The hardware of the automatic meter reading and theft control system by using GSM module our project at designing such a system which will automatically collect the reading and also detect the theft. Current transformer is used to measure the total power consumption for house or industrial purpose. This recorded reading is transmitted to the electricity board as per his demand for transmitting the reading of energy meter GSM module is used.

The energy theft is control by IR sensor, IR is placed in the screw portion of energy meter seal. If the screw is removed from the meter message is send to the electricity board. The measuring of energy meter and monitoring of IR sensor is done with a PIC microcontroller. Then bypass of meter is detected by using to CT. One is in energy meter another is placed on electricity pole.

4.1 BLOCK DIAGRAM

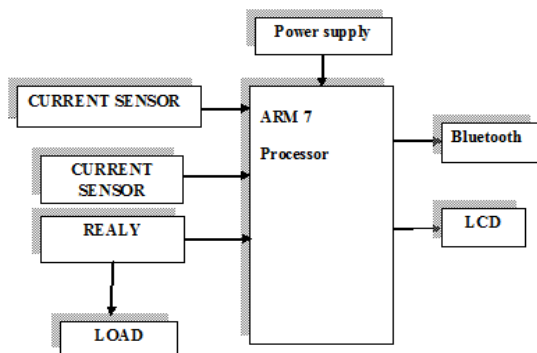

Fig 1 Block Diagram

4.2 Working

4.3 Flow Chat

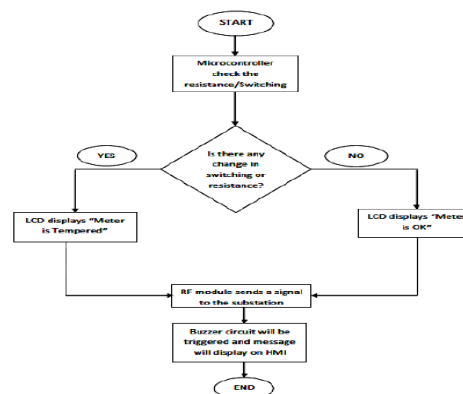

Figure 2 Flow Chart

RESULT ANALYSIS

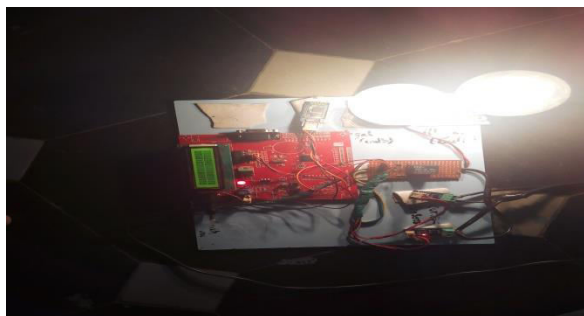

Fig 3 Kit Diagram

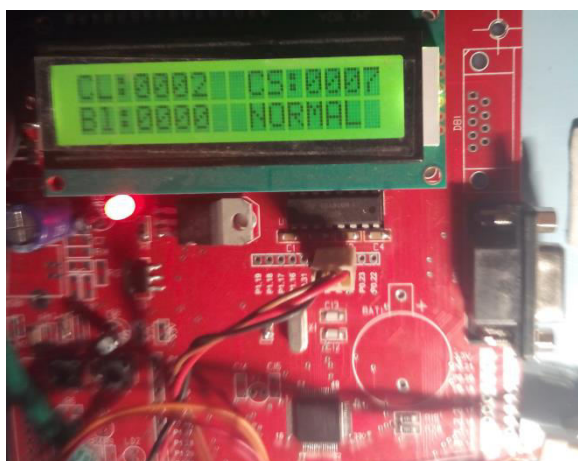

Fig 3 Kit Diagram for normal

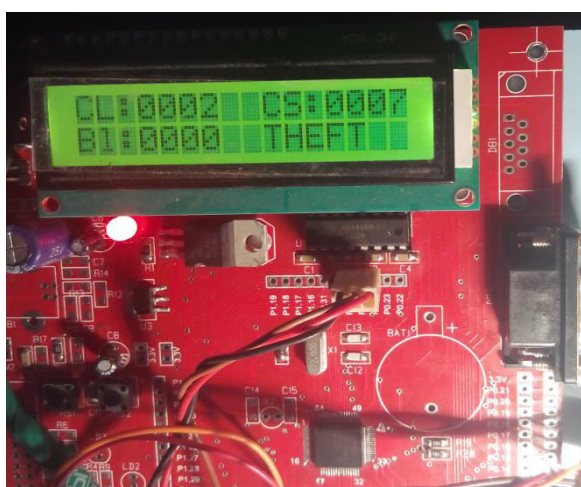

Fig 3 Kit Diagram for Theft

5. CONCLUSION AND FUTURE ENHANCEMENT

The evidence points to the increasing levels of power theft in many countries and the financial losses for some systems are so immense that the utility is in financial turn over. Investment in improving the system and adding additional capacity cannot be undertaken, loans and payments cannot be met, and the consumer faces increased electricity charges. Even in efficient systems, theft losses can account for millions of dollars each year in lost revenue. Electricity theft in its various forms can be reduced and kept in check only by the strong and assertive action of power sector. The strategy and the action should be based upon a thorough understanding of the specific nature of the theft problem. Finally the proposed work is implemented on hardware. As the substation side there is data base master computer in which it keeps all the record of each house, also proposed work is capable of give the information regarding that particular address of home where electricity theft is occurring.

REFERENCES

- [1] J. Nagi, K. S. Yap, S. K. Tiong, S. K. Ahmed, M. Mohamad, "Nontechnical loss detection for metered customers in power utility using support vector machines", IEEE Trans.



Power Del., vol. 25, no. 2, pp. 1162–1171, Apr. 2010.

[2] A. H. Nizar, Z. Y. Dong, and Y. Wang, “Power utility nontechnical loss analysis with extreme learning machine model”, IEEE Trans. Power Syst., vol. 23, no. 3, pp. 946–955, Aug. 2008.

[3] C. R. Paul, “System loss in a Metropolitan utility network” IEEE Power Engineering Journal, pp. 305–307, Sept. 1987.

[4] [Http://Www.Freshpatents.Com/Power-Theft-Detection-System-And-Method](http://www.freshpatents.com/power-theft-detection-system-and-method).

[5] [Http://Www.Freshpatents.Com/Power-Theft Detection-System-And-Method](http://www.freshpatents.com/power-theft-detection-system-and-method)
Dt20080508ptan20080109387.Php

[6]
[Http://Www.Electronicmanufacturers.Com/Products/Electrical-Electronic Components/Transformer/Current-Transformer](http://www.electronicmanufacturers.com/products/electrical-electronic-components/transformer/current-transformer)