

## COPY RIGHT

**2018 IJIEMR.** Personal use of this material is permitted. Permission from IJIEMR must be obtained for all other uses, in any current or future media, including reprinting/republishing this material for advertising or promotional purposes, creating new collective works, for resale or redistribution to servers or lists, or reuse of any copyrighted component of this work in other works. No Reprint should be done to this paper, all copy right is authenticated to Paper Authors

IJIEMR Transactions, online available on 24<sup>th</sup> January 2018. Link :

<http://www.ijiemr.org/downloads.php?vol=Volume-7&issue=ISSUE-01>

Title: Analysis of the performance of Active Type SFCL and FCL for Reducing the Fault Current and Overvoltage in a Distribution System.

Volume 07, Issue 01, Page No: 197 – 203.

Paper Authors

\* **SHAIK SADHIQ , B.KOTESWARA RAO.**

\* Dept of EEE, V.N.R. engineering college.



USE THIS BARCODE TO ACCESS YOUR ONLINE PAPER

To Secure Your Paper As Per **UGC Guidelines** We Are Providing A Electronic Bar Code

## ANALYSIS OF THE PERFORMANCE OF ACTIVE TYPE SFCL AND FCL FOR REDUCING THE FAULT CURRENT AND OVERVOLTAGE IN A DISTRIBUTION SYSTEM

**\*SHAIK SADHIQ , \*\* B.KOTESWARA RAO**

\*PG Scholar, Dept of EEE, V.N.R. engineering college,Ponnur, Guntur (Dt); A.P, India.

\*\*Assistant Professor, Dept of EEE, V.N.R. engineering college,Ponnur, Guntur (Dt); A.P, India.

### ABSTRACT-

Distributed Generation Resources are increasingly used in distribution systems due to their great advantages. The presence of DG, however, can cause various problems such as miss-coordination, false tripping, blinding and reduction of reach of protective devices. Using superconducting fault current limiters (SFCLs) is one of the best methods to minimize these problems comparing to the other conventional methods. The active SFCL can as well suppress the short-circuit current induced by a three-phase grounded fault effectively, and the power system's safety and reliability can be improved and it is composed of an air-core superconducting transformer and a PWM converter. The magnetic field in the air-core can be controlled by adjusting the converters output current, and then the active SFCLs equivalent impedance can be regulated for current limitation and possible overvoltage suppression. During the study process, in view of the changes in the locations of the DG units connected to the system, the DG units injection capacities and the fault positions, the active SFCLs and FCLs current-limiting and over voltages suppressing characteristics are presented by using Matlab/simulink software.

### I. INTRODUCTION

In recent years, with the great development of interconnected power grid, the power network structure becomes increasingly complicated, and the system short circuit capacity and short circuit current have reached a new level which could exceed the allowable currents of the circuit breakers. The introduction of DG into a distribution network may bring lots of advantages, such as emergency backup and peak shaving. However, the presence of these sources will lead the distribution network to lose its radial nature, and the fault current level will increase. When a single-phase grounded fault happens in a distribution system with isolated neutral, over voltages will be induced on the other two health phases, and in consideration of the installation of multiple DG units, the impacts of the induced over voltages on the distribution network's insulation stability and operation safety should be taken into account seriously. The increase of the fault current has imposed a

severe burden on the related machinery in the grid, and the stability of the power system is also damaged.

The fault current limiters (FCL) are regarded as the suitable solution to solve excessive fault current problems. Active superconducting fault current limiter (ASFCL) voltage compensation type is a novel topology of FCL. This type SFCL not only preserves the merits of bridge type SFCL such as the automatic switch to the current limiting mode and without the quench of the superconductor, but also has the particular abilities of controlling the steady fault current and compensating active and reactive power for AC main circuit in the normal state.

In view of that the introduction of a SFCL can impact the coefficient of grounding, which is a significant contributor to control the induced overvoltage's amplitude, the change of the coefficient may bring positive effects on restraining over voltages. We have proposed a

voltage compensation type active SFCL. In previous work and analyzed the active SFCL's control strategy and its influence on relay protection.

## II. THEORETICAL ANALYSIS

### A. Structure and Principle of the Active SFCL

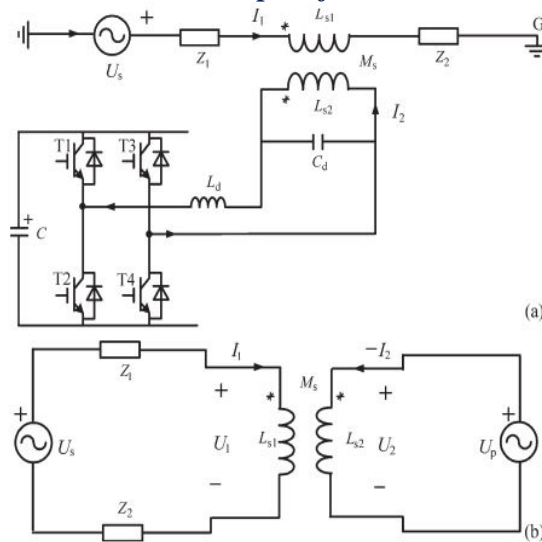

Fig.1. Single-phase voltage compensation type active SFCL. (a) Circuit structure and (b) equivalent circuit.

As shown in Fig. 1(a), it denotes the circuit structure of the single-phase voltage compensation type active SFCL, which is composed of an air-core superconducting transformer and a voltage-type PWM converter.  $L_{s1}$ ,  $L_{s2}$  are the self-inductance of two superconducting windings, and  $M_s$  is the mutual inductance.  $Z_1$  is the circuit impedance and  $Z_2$  is the load impedance.  $L_d$  and  $C_d$  are used for filtering high order harmonics caused by the converter. Since the voltage-type converter's capability of controlling power exchange is implemented by regulating the voltage of AC side, the converter can be thought as a controlled voltage source up. By neglecting the losses of the transformer, the active SFCL's equivalent circuit is shown in Fig. 1(b).

In normal (no fault) state, the injected current ( $I_2$ ) in the secondary winding of the transformer will be controlled to keep a certain value, where the magnetic field in the air-core can be compensated to zero, so the active SFCL will have no influence on the main circuit. When the fault is detected, the injected current will be timely adjusted in amplitude or phase angle, so as to control the superconducting transformer's primary voltage which is in series with the main circuit, and further the fault current can be suppressed to some extent. Below, the suggested SFCL's specific regulating mode is explained. In normal state, the two equations can be achieved.

$$\dot{U}_s = \dot{I}_1(Z_1 + Z_2) + j\omega L_{s1}\dot{I}_1 - j\omega M_s\dot{I}_2 \quad (1)$$

$$\dot{U}_p = j\omega M_s\dot{I}_1 - j\omega L_{s2}\dot{I}_2. \quad (2)$$

Controlling  $I_2$  to make  $j\omega L_{s1}I_1 - j\omega M_s I_2 = 0$  and the primary voltage  $U_1$  will be regulated to zero. Thereby, the equivalent limiting impedance  $Z_{SFCL}$  is zero ( $Z_{SFCL} = U_1/I_1$ ), and  $I_2$  can be set as  $I_2 = \dot{U}_s \sqrt{L_{s1}/L_{s2}} / (Z_1 + Z_2) k$ , where  $k$  is the coupling coefficient and it can be shown as  $k = M_s / \sqrt{L_{s1} L_{s2}}$ . Under fault condition ( $Z_2$  is shorted), the main current will rise from  $I_1$  to  $I_{1f}$ , and the primary voltage will increase to  $U_{1f}$ .

$$\dot{I}_{1f} = \frac{(\dot{U}_s + j\omega M_s \dot{I}_2)}{(Z_1 + j\omega L_{s1})} \quad (3)$$

$$\begin{aligned} \dot{U}_{1f} &= j\omega L_{s1}\dot{I}_{1f} - j\omega M_s\dot{I}_2 \\ &= \frac{\dot{U}_s(j\omega L_{s1}) - \dot{I}_2 Z_1(j\omega M_s)}{Z_1 + j\omega L_{s1}} \end{aligned} \quad (4)$$

The current-limiting impedance  $Z_{SFCL}$  can be controlled in:

$$Z_{SFCL} = \frac{\dot{U}_{1f}}{\dot{I}_{1f}} = j\omega L_{s1} - \frac{j\omega M_s \dot{I}_2 (Z_1 + j\omega L_{s1})}{\dot{U}_s + j\omega M_s \dot{I}_2} \quad (5)$$

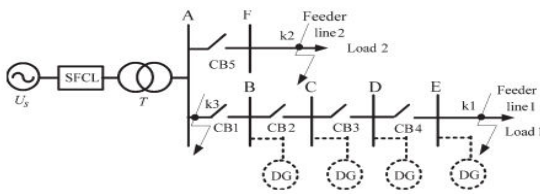

Fig.2. Application of the active SFCL in a distribution system with DG units.

According to the difference in the regulating objectives of  $I_2$ , there are three operation modes:

- 1) Making  $I_2$  remain the original state, and the limiting impedance  $Z_{SFCL-1}=Z_2$  ( $j\omega L_{s1}$ )/( $Z_1+Z_2+j\omega L_{s1}$ ).
- 2) Controlling  $I_2$  to zero, and  $Z_{SFCL-2}=j\omega L_{s1}$ .
- 3) Regulating the phase angle of  $I_2$  to make the angle difference between  $U_s$  and  $j\omega M_s I_2$  be  $180^\circ$ . By setting  $j\omega M_s I_2 = -cU_s$ , and  $Z_{SFCL-3}=cZ_1/(1-c) + j\omega L_{s1}/(1-c)$ .

The air-core superconducting transformer has many merits, such as absence of iron losses and magnetic saturation, and it has more possibility of reduction in size, weight and harmonic than the conventional iron-core superconducting transformer. Compared to the iron-core, the air-core can be more suitable for functioning as a shunt reactor because of the large magnetizing current, and it can also be applied in an inductive pulsed power supply to decrease energy loss for larger pulsed current and higher energy transfer efficiency.

There is no existence of transformer saturation in the air-core, and using it can ensure the linearity of ZSFCL well.

### B. Applying the SFCL into a Distribution Network with DG

As shown in Fig. 2, it indicates the application of the active SFCL in a distribution network with multiple DG units, and the buses B-E are the DG units' probable installation locations. When a single-phase grounded fault occurs in the feeder line 1 (phase A, k1 point), the SFCL's mode 1 can be automatically triggered, and the fault current's rising rate can

be timely controlled. Along with the mode switching, its amplitude can be limited further. In consideration of the SFCL's effects on the induced overvoltage, the qualitative analysis is presented. In order to calculate the over voltages induced in the other two phases (phase B and phase C), the symmetrical component method and complex sequence networks can be used, and the coefficient of grounding  $G$  under this condition can be expressed as  $G=-1.5m/(2+m) \pm j \sqrt{3}/2$ , where  $m=X_0/X_1$ , and  $X_0$  is the distribution network's zero-sequence reactance,  $X_1$  is the positive-sequence reactance. Further, the amplitudes of the B-phase and C-phase over voltages can be described as:

$$U_{BO} = U_{CO} = \sqrt{3} \left| \frac{\sqrt{G^2 + G + 1}}{G + 2} \right| U_{AN} \quad (6)$$

### C. Superconducting Fault Current Limiter

Superconducting Fault Current Limiter (SFCL) is innovative electric equipment which has the capability to reduce the fault current level within the first cycle of fault current [1]. The first-cycle suppression of fault current by a SFCL results in an increased transient stability of the power system carrying higher power with greater stability. The concept of using the superconductors to carry electric power and to limit peak currents has been around since the discovery of superconductors and the realization that they possess highly non-linear properties. More specifically, the current limiting behavior depends on their nonlinear response to temperature, current and magnetic field variations. Increasing any of these three parameters can cause a transition between the superconducting and the normal conducting regime. The term —quench‖ is commonly used to describe the propagation of the normal zone through a superconductor. Once initiated, the quench process is often rapid and uncontrolled. Though once initiated the quench process is uncontrolled, the extent of the normal region and the temperature rise in the materials can be predicted.

### III. FAULT CURRENT LIMITER

Fig. 3 shows the circuit topology of the proposed FCL which is composed of the two following parts:

- 1) Bridge part that includes a diode rectifier bridge, a small dc limiting reactor. (Note that its resistance is involved too.), a semiconductor switch (IGBT or GTO), and a freewheeling diode.
- 2) Shunt branch as a compensator that consists of a resistor and an inductor.

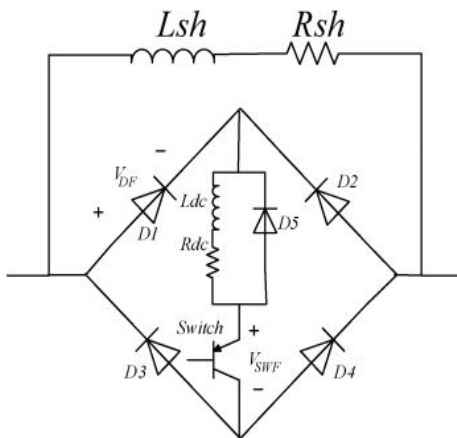

Fig. 3. Proposed FCL topology

The total power losses of the proposed structure become a very small percentage of the feeder's transmitted power.

### IV. MATLAB/SIMULINK RESULTS

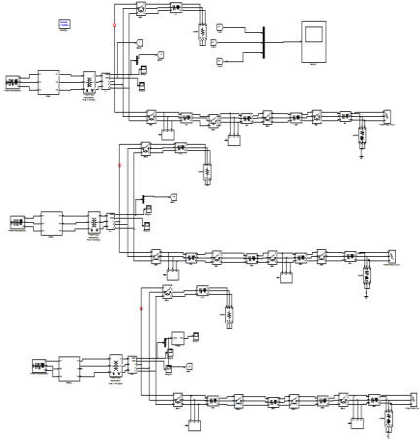

Fig.4 Matlab/Simulink Model of Proposed Distribution System with Distributed

Generation Units without any compensation scheme using Active SFCL methodology.

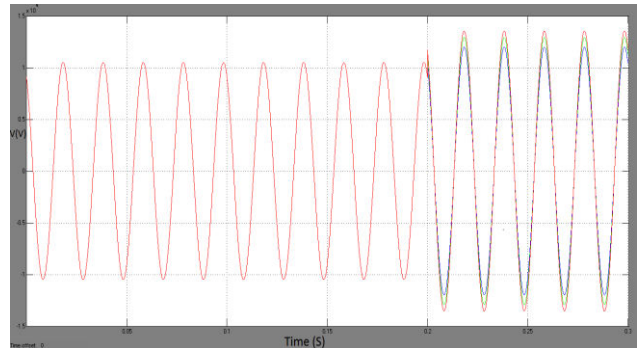

Fig.5 Voltage characteristics of the Bus-A under different locations of DG units without SFCL.

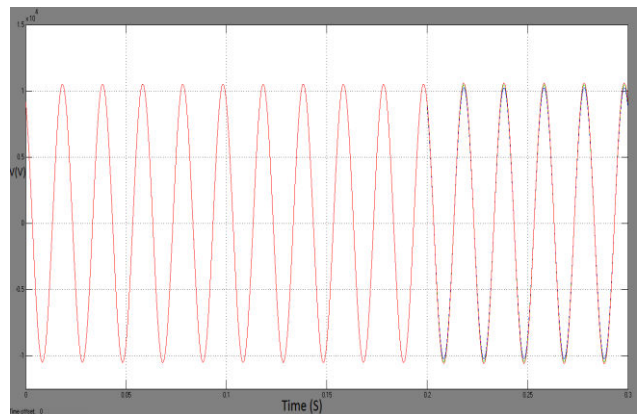

Fig.6 Voltage characteristics of the Bus-A under different locations of DG units with SFCL.

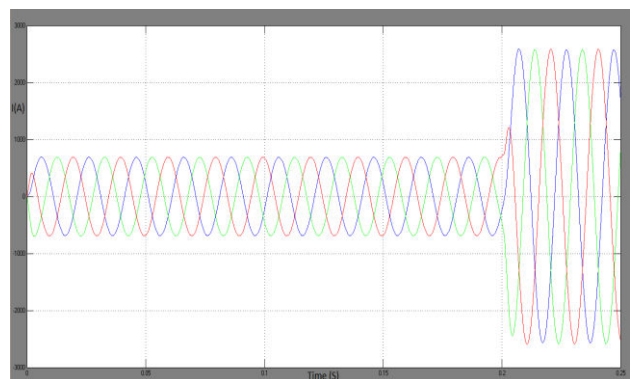

Fig. 7 Line current waveforms when the three-phase short-circuit occur at k3 point without SFCL.

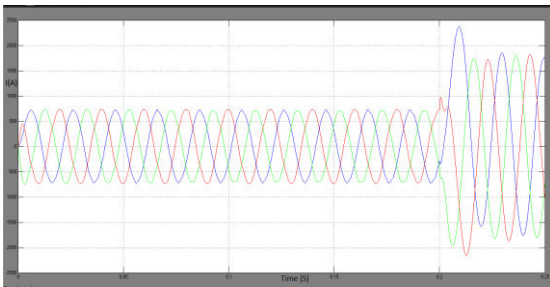

Fig. 8 Line current waveforms when the three-phase short-circuit occur at k3 point with SFCL.

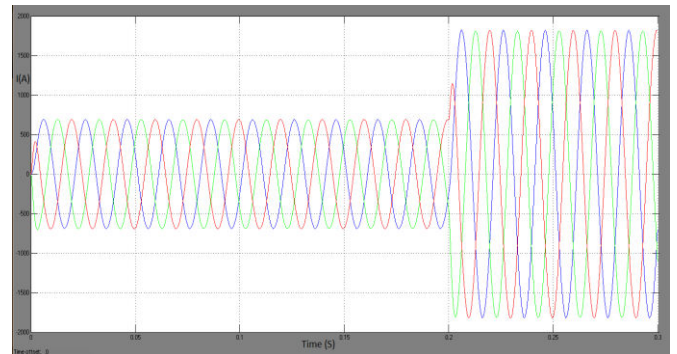

Fig.12 Active SFCL's current-limiting performances with fault location at k2 point.

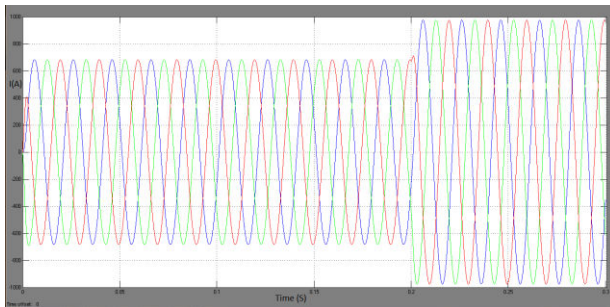

Fig.9. Current Waveform with fault location at k1 point without Active SFCL.

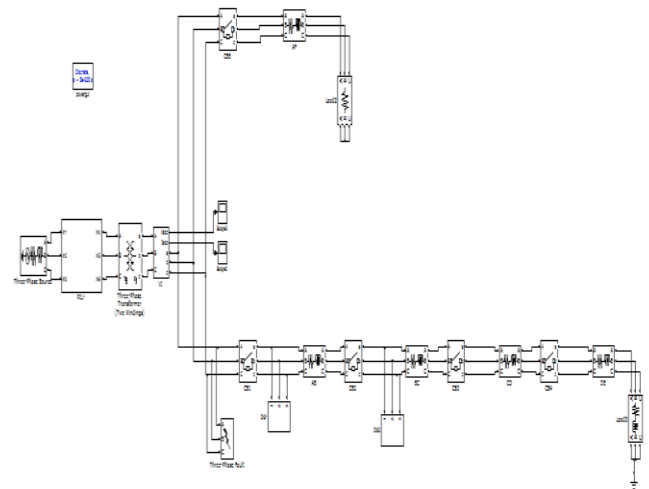

Fig.13 Matlab/Simulink Model of Proposed Distribution System with Distributed Generation units using FCL methodology.

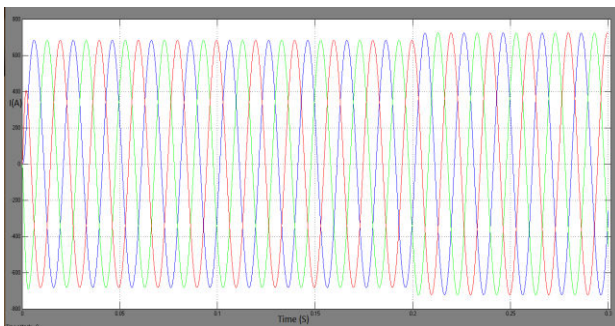

Fig.10 Active SFCL's current-limiting performances with fault location at k1 point.

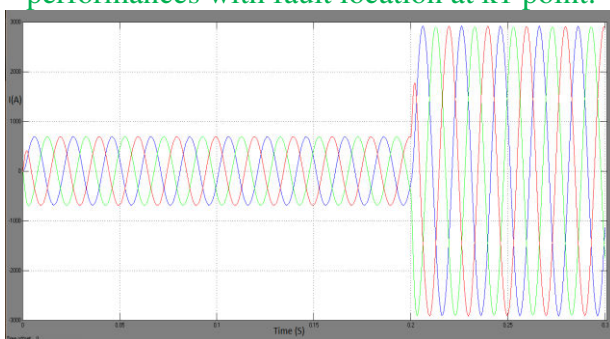

Fig.11 Current Waveform with fault location at k2 point without Active SFCL

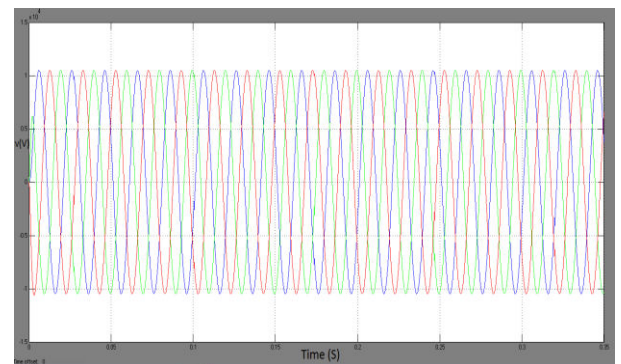

Fig.14. Line voltage waveforms when the three-phase short-circuit occur at k3 point with FCL.

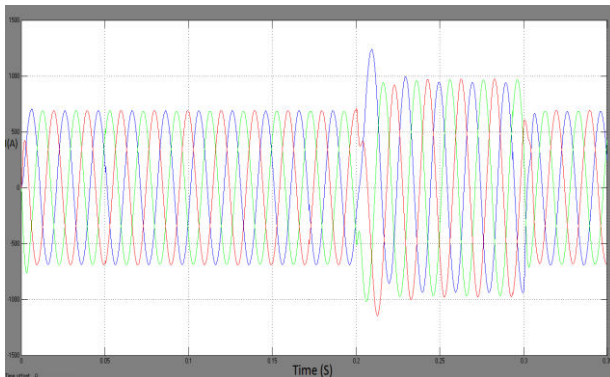

Fig.15.Line current waveforms when the three-phase short-circuit occur at k3 point with FCL.

## V.CONCLUSION

This paper is the quick review of Distributed Generation in India, its need, importance in near future. This paper provides how Traditional Generation is differing from Distributed Generation. In this paper, a comparative analysis of the active SFCL and FCL in a power distribution network with DG units is investigated. For the power frequency overvoltage caused by a single-phase grounded fault, the active SFCL can help to reduce the overvoltage's amplitude and avoid damaging the relevant distribution equipment. But from the simulation analysis the FCL can as well suppress the short-circuit current induced by a three-phase grounded fault effectively compared to the Active SFCL, and the power system's safety and reliability can be improved. In recently years, more and more dispersed energy sources, such as wind power and photovoltaic solar power, are installed into distribution systems. Therefore, the study of a coordinated control method for the renewable energy sources and the FCL becomes very meaningful, and it will be performed in future.

## REFERENCES

[1] S. Conti, "Analysis of distribution network protection issues in presence of dispersed generation," *Elect. Power Syst. Res.*, vol. 79, no. 1, pp. 49–56, Jan. 2009.

[2] A. S. Emhemed, R. M. Tumilty, N. K. Singh, G. M. Burt, and J. R. McDonald, "Analysis of transient stability enhancement of LV connected induction micro generators by using resistive-type fault current limiters," *IEEE Trans. Power Syst.*, vol. 25, no. 2, pp. 885–893, May 2010.

[3] S.-Y. Kim and J.-O. Kim, "Reliability evaluation of distribution network with DG considering the reliability of protective devices affected by SFCL," *IEEE Trans. Appl. Supercond.*, vol. 21, no. 5, pp. 3561–3569, Oct. 2011.

[4] S. A. A. Shahriari, A. Yazdian, and M. R. Haghifam, "Fault current limiter allocation and sizing in distribution system in presence of distributed generation," in *Proc. IEEE Power Energy Soc. Gen. Meet., Calgary, AB, Canada, Jul. 2009*, pp. 1–6.

[5] S. Hemmati and J. Sadeh, "Applying superconductive fault current limiter to minimize the impacts of distributed generation on the distribution protection systems," in *Proc. Int. Conf. Environ. Electr. Eng., Venice, Italy, May 2012*, pp. 808–813.

[6] S.-H. Lim, J.-S. Kim, M.-H. Kim and J.-C. Kim, "Improvement of protection coordination of protective devices through application of a SFCL in a power distribution system with a dispersed generation," *IEEE Trans. Appl. Supercond.*, vol. 22, no. 3, p. 5601004, Jun. 2012.

[7] L. Chen, Y. Tang, J. Shi, and Z. Sun, "Simulations and experimental analyses of the active superconducting fault current limiter," *Phys. C*, vol. 459, no. 1/2, pp. 27–32, Aug. 2007.

[8] L. Chen, Y. Tang, J. Shi, Z. Li, L. Ren, and S. Cheng, "Control strategy for three-phase four-wire PWM converter of integrated voltage compensation type active SFCL," *Phys. C*, vol. 470, no. 3, pp. 231–235, Feb. 2010.

[9] L. Chen, Y. J. Tang, J. Shi, L. Ren, M. Song, S. J. Cheng, Y. Hu, and



X. S. Chen, “Effects of a voltage compensation type active superconducting fault current limiter on distance relay protection,” *Phys. C*, vol. 470, no. 20, pp. 1662–1665, Nov. 2010.

[10] J. Wang, L. Zhou, J. Shi, and Y. Tang, “Experimental investigation of an active superconducting current controller, ”*IEEE Trans. Appl. Super cond.*, vol. 21, no. 3, pp. 1258–1262, Jun. 2011.